







Installation Instructions

Power Step Extension for Lifted Trucks

Vehicle Application

- Works with these Bestop Power Steps
75010, 75102, 75103, 75104, 75108
Part Number: 75130

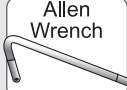
www.Bestop.com - We're here to help! Visit our web site and click on ["Ask a Question"](#). Click here for more [Truck Accessories by Bestop](#).

INSTALLATION TIME	SKILL LEVEL
 1/2 Hour	 1 - Easy
TOOLS	
 Allen Wrench 3/16"	 Safety Glasses



! WARNING

This product is designed primarily to enhance the appearance of the vehicle and to shield the occupants from ordinary weather conditions. Do not rely in any way on the components of this product to contain occupants within the vehicle, or to protect against injury or death in the event of an accident. This product will not protect the occupants from falling objects. Never operate the vehicle in excess of manufacturer's specifications.

WEAR SEAT BELTS AT ALL TIMES

Read and follow, precisely, all installation instructions provided when installing product. Failure to do so may result in a poor fit and could place occupants of the vehicle in a potentially dangerous situation.

Power Step Extension – Installation Instructions

Parts List and Hardware Identification

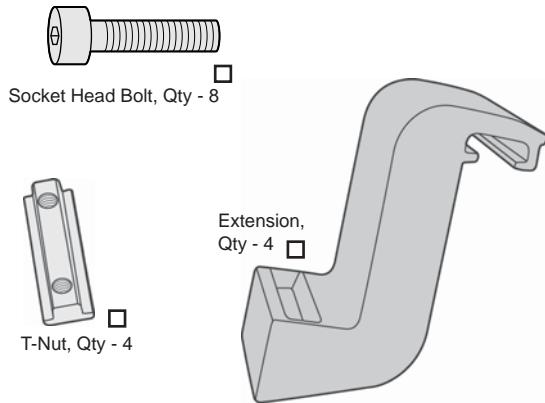

2 Install Extensions on Power Step Arms

If the Power Steps are installed on the vehicle, remove the Socket Head Bolts that secure them to the Arms and set them aside to be reused later.

Place an Extension onto one of the arms so that the T-Nut aligns with the holes in the arms.

Re-install the Socket Head Bolts. Use a 3/16" Allen Wrench to tighten the bolts to 10 ft./lbs. (13.5 Nm).

Repeat this with all four Extensions.

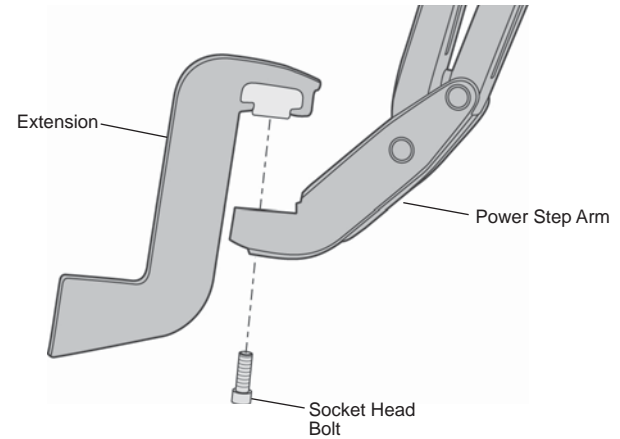

1 Slide T-Nuts into Extensions

Slide the T-Nuts in the parts kit into the slots in the Extensions.

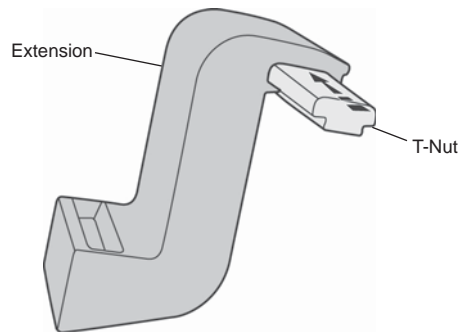

3 Install Steps

Slide a Step onto the Extensions on one side of the vehicle so that the T-Nut aligns with the holes in the Extensions.

Install four Socket Head Bolts. Use a 3/16" Allen Wrench to tighten the bolts to 10 ft./lbs. (13.5 Nm).

Repeat on the other side of the vehicle.

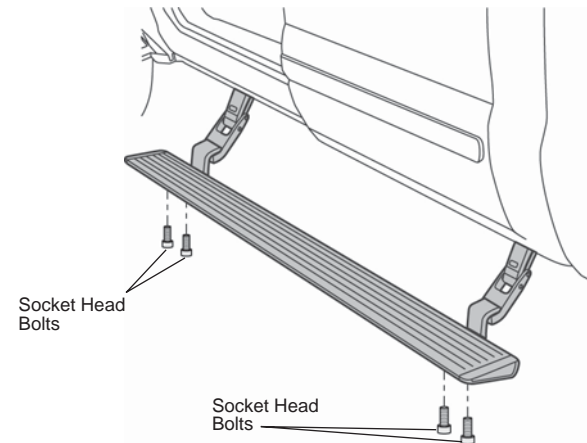

Power Step Extension – Installation Instructions

Limited Warranty

We warrant our product to be free from defects in material and workmanship, for the terms specified below, provided there has been normal use and proper maintenance. This warranty applies to the original purchaser only. All remedies under this warranty are limited to the repair or replacement of any item or items found by the factory to be defective within the time period specified.

If you have a warranty claim, first you must call our factory at the number below for instructions. You must retain proof of purchase and submit a copy with any items returned for warranty work. Upon completion of warranty work, if any, we will return the repaired or replaced item or items to you freight prepaid. Damage to our products caused by accidents, fire, vandalism, negligence, misinstallation, misuse, Acts of God, or by defective parts not manufactured by us, is not covered under this warranty.

THE WARRANTY TIME PERIOD IS AS FOLLOWS: ALL "SOFT GOODS" MANUFACTURED BY OUR COMPANY (USING PRIMARILY VINYL, PLASTICS, AND/OR FOAM): ONE YEAR FROM DATE OF PURCHASE.

ANY IMPLIED WARRANTIES OF MERCHANTABILITY AND/OR FITNESS FOR A PARTICULAR PURPOSE CREATED HEREBY ARE LIMITED IN DURATION TO THE SAME DURATION AND SCOPE AS THE EXPRESS WRITTEN WARRANTY. OUR COMPANY SHALL NOT BE LIABLE FOR ANY INCIDENTAL OR CONSEQUENTIAL DAMAGE.

Some states do not allow limitations on how long an implied warranty lasts, or the exclusion or limitation of incidental or consequential damages, so the above limitations or exclusions may not apply to you.

This warranty gives you specific legal rights, and you may also have other rights which vary from state to state.



For further information or request for warranty work, please contact:
Bestop Inc. Customer Service
(800) 845-3567
(303) 465-1755