











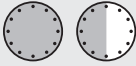



Installation Instructions Supertop®

Vehicle Application

- Jeep CJ8 Scrambler
1981 – 1985
Part Number: 54608

www.Bestop.com - We're here to help! Visit our web site and click on ["Ask a Question"](#). Click here for more [Jeep Accessories by Bestop](#).

INSTALLATION TIME	SKILL LEVEL
	
1-1/2 Hours	3 - Moderately Difficult

TOOLS			
 Power Drill <small>1/8", 5/32", 7/32" and 3/8"</small>	 Center Punch	 Ratchet	 Adjustable Wrench
 Flat-Head Screwdriver	 Phillips Screwdriver	 Hammer	 Pencil
 Tape Measure <small>10'</small>	 Safety Glasses		

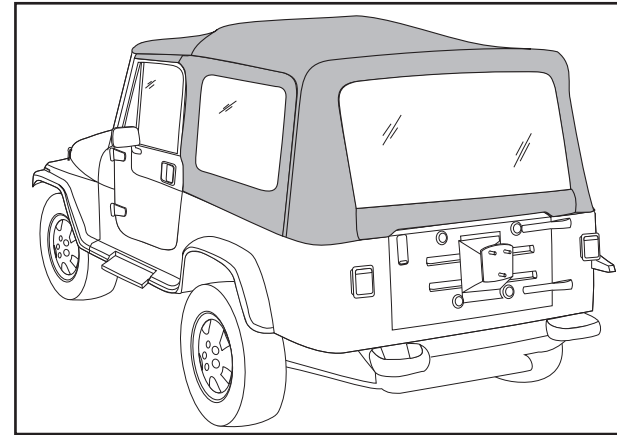

 **CAUTION** Safety glasses should be worn at all times while installing this product.

Installation Tips

Before you begin installing this assembly, read all instructions thoroughly.

For a smooth fit:

For ease in installation, the product should be installed at temperatures above 72° F. Below this temperature, the fabric may contract an inch or more, making it difficult to fit to the vehicle. It is normal for fabric to contract and wrinkle when stored in the shipping carton. Within a few days after the installation, the fabric will relax and the wrinkles will disappear.

 **WARNING** This product is designed primarily to enhance the appearance of the vehicle and to shield the occupants from ordinary weather conditions. Do not rely in any way on the components of this product to contain occupants within the vehicle, or to protect against injury or death in the event of an accident. This product will not protect the occupants from falling objects. Never operate the vehicle in excess of manufacturer's specifications.

WEAR SEAT BELTS AT ALL TIMES

Read and follow, precisely, all installation instructions provided when installing product. Failure to do so may result in a poor fit and could place occupants of the vehicle in a potentially dangerous situation.

Supertop® – Installation Instructions

Top Fabric	Qty - 1
Quarter Window, Right	Qty - 1
Quarter Window, Left	Qty - 1
Rear Window	Qty - 1

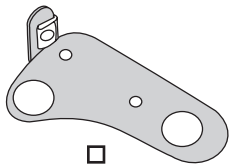

Windshield Bracket - Left, Qty - 1, Part Number 137.97

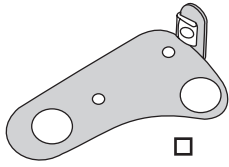

Windshield Bracket - Right, Qty - 1, Part Number 137.96

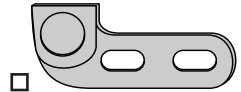

Vertical Retainer Mount, Right, Qty - 1, Part Number 229.24

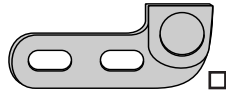

Vertical Retainer Mount, Left, Qty - 1, Part Number 229.25

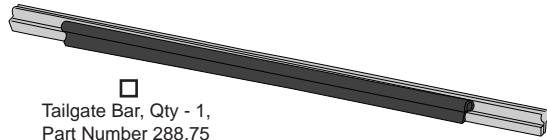

Tailgate Bar, Qty - 1, Part Number 288.75

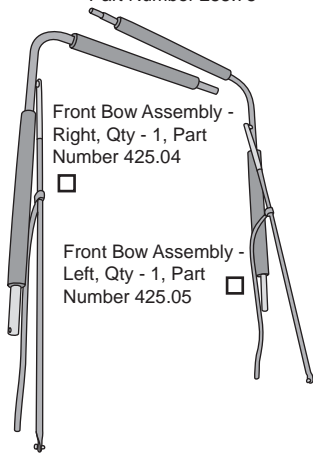

Front Bow Assembly - Right, Qty - 1, Part Number 425.04

Front Bow Assembly - Left, Qty - 1, Part Number 425.05

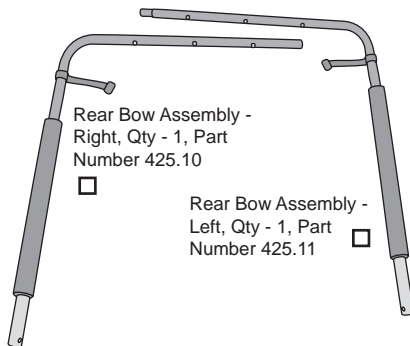

Rear Bow Assembly - Right, Qty - 1, Part Number 425.10

Rear Bow Assembly - Left, Qty - 1, Part Number 425.11

Parts List and Hardware Identification

Windshield Retainer - Right, Qty - 1, Part Number 225.42

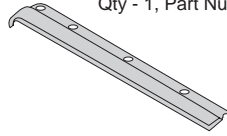

Windshield Retainer - Left, Qty - 1, Part Number 225.43

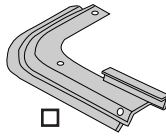
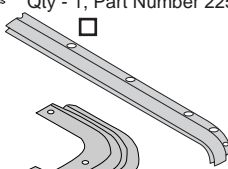

Corner Belt Rail, Left, Qty - 1, Part Number 288.34

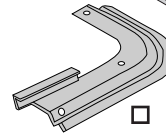

Corner Belt Rail, Right, Qty - 1, Part Number 288.33

Front Side Belt Rail - Left, Qty - 1, Part Number 425.01

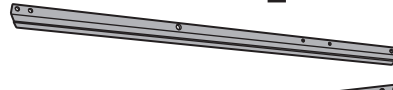

Front Side Belt Rail - Right, Qty - 1, Part Number 425.00



#8 x 1/2" Pan Head Washer Screw - Black, Qty - 13, Part Number 200.48



#10 x 1/2" Pan Head Sheet Metal Screw, Qty - 4, Part Number 1.92

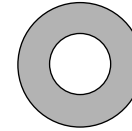

5/16" Black Washer, Qty - 16, Part Number 233.04

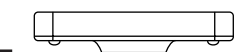
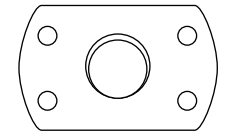

5/16-18 Tapping Plate, Qty - 16, Part Number 200.50

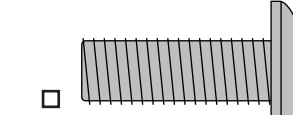

5/16-18 x 1" Phillips Head Bolt, Qty - 16, Part Number 236.20

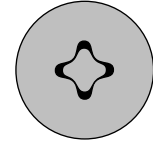

Bow Mounting Kit, Packaged together, Part Number 182.76

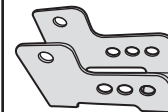

Bow Mount Bracket, Qty 2



#10 x 1/2" Self Tapping Screw, Qty 4

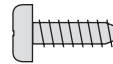

Clevis Pin, Qty 4



Hairpin Clevis Keeper, Qty 4

Supertop® – Installation Instructions

NOTE If you are replacing an old soft top, be certain that all parts of the old top are removed, including the windshield retainer. Old metal parts are not compatible with the new Supertop. Using parts other than those provided in your Supertop kit can result in personal injury and/or damage to the vehicle and soft top.

WARNING Improper windshield adjustment will result in poor fitting top and doors, causing looseness or undue strain on the top.

Windshield Measurement

Before installing the top, check the windshield measurement. The distance from the top lip of the windshield to the top outer edge of the body must be 97-3/4" on both sides of the vehicle. Measure 4" - 6" inside the doors.

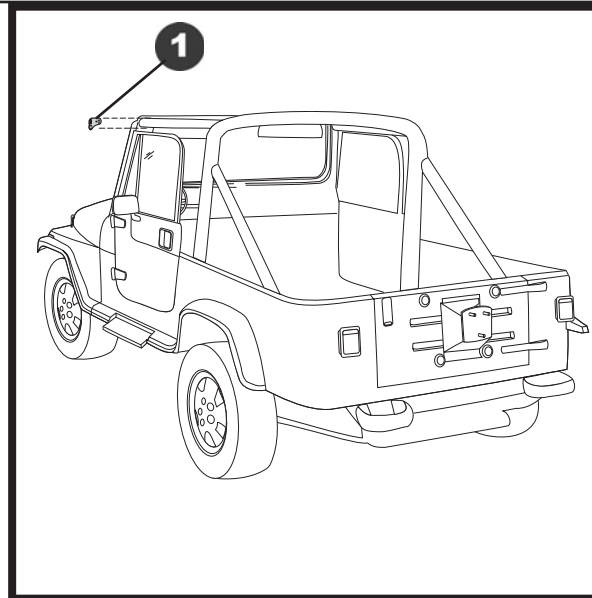
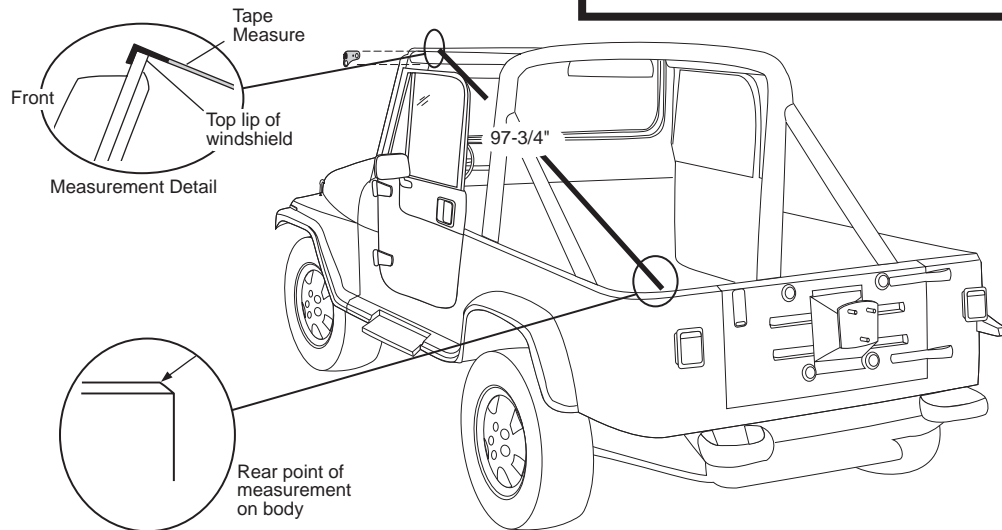

1 Install Windshield Brackets

After adjusting the windshield, install the Windshield Brackets. If present remove the outboard sun visor fasteners on both sides of the windshield frame. Place the Windshield Brackets flush with the frame on the upper corners of the windshield. Use the bracket as a template to mark, center punch and drill two 5/32" holes for each bracket. Mount each bracket to the windshield frame using two #10 x 1/2" Pan Head Sheet Metal Screws. Reinstall sun visor brackets.

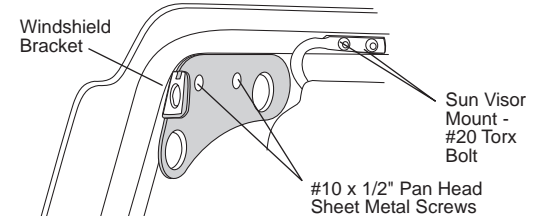

Windshield Adjustment: If necessary, loosen the two screws in the Windshield Clamps at the base of the windshield on each side of the vehicle. Adjust the windshield forward or back, use a shim if needed to position the windshield, and tighten the screws.

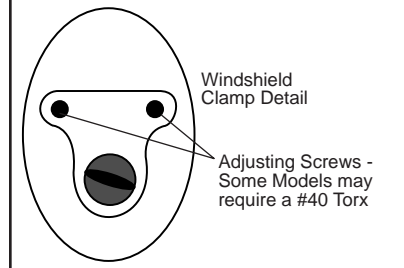

Supertop® – Installation Instructions

! WARNING

A loose Windshield Retainer may allow the top to disengage from the windshield, causing damage to the top and possible injury to the occupants of the vehicle.

Make certain that the Windshield Retainer is securely fastened to the windshield during installation and at all other times by checking the tightness of the mounting screws every three months.

Do not use any drill size other than 1/8". Failure to use the correct size may cause the Windshield Retainer to loosen.

2 Install Windshield Retainer

Position the two piece Windshield Retainer on top of windshield frame. Use retainer pieces as templates to mark, center punch and drill eleven 1/8" holes. Install with eleven #8 x 1/2" Pan Head Screws.

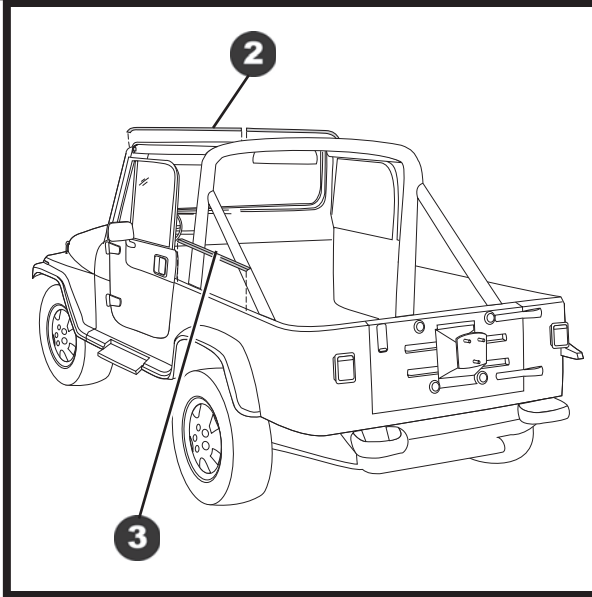
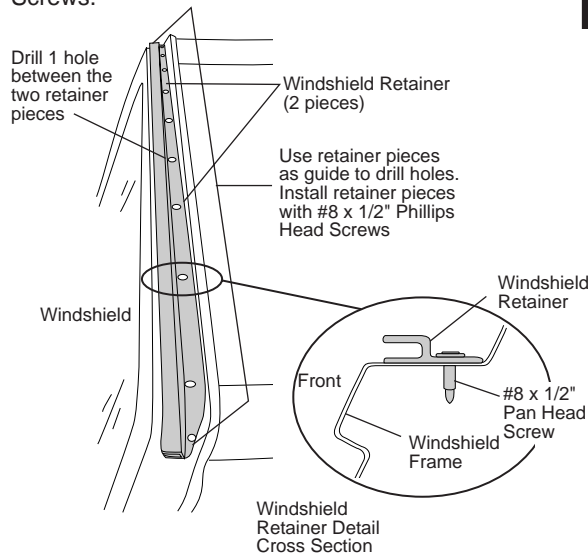

! CAUTION

When drilling in the top edge of the vehicle body, check underneath for wiring for the rear lights. Pull the wiring out of the way before drilling.

3 Install Front Side Belt Rails

Use a straight edge to extend the top outer rear edge of the body outward and measure 67-7/16" from the rear edge of the body. Mark this location on the top edge of the body on both sides of the vehicle. Set the Left Front Side Belt Rail on the left side of the vehicle with the front hole in the rail over the mark. Use the rail as a template to mark the remaining three 3/8" holes. Center punch and drill four (4) 3/8" holes at the marked locations. Install the rail with a 5/16" Phillips Head Bolt, a 5/16" Washer and a 5/16" Tapping Plate in the rear and middle holes. Do not tighten the bolts yet.

Repeat with the Right Front Side Belt Rail.

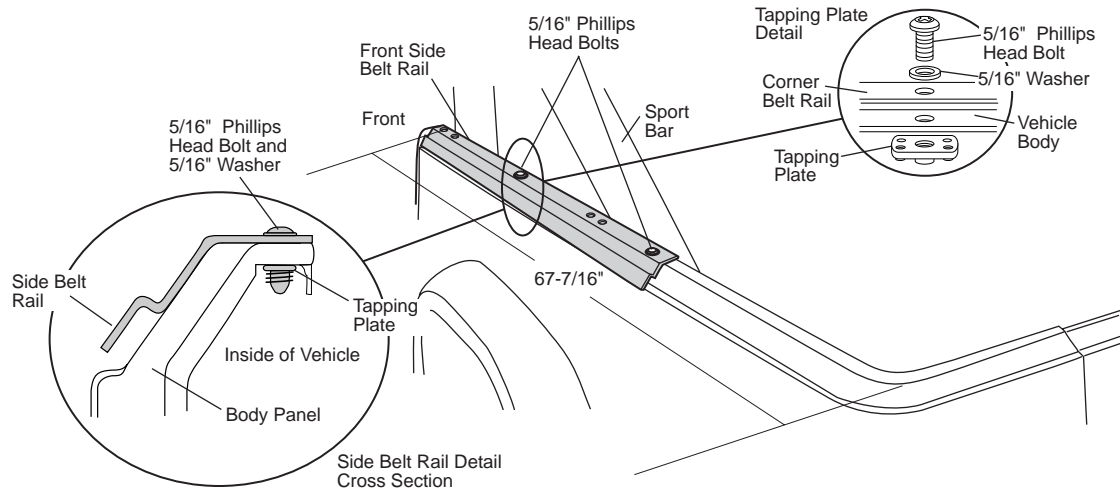

Supertop® – Installation Instructions



CAUTION

When drilling in the top edge of the vehicle body, check underneath for wiring for the rear lights. Pull the wiring out of the way before drilling.



4 Install Rear Corner Belt Rails

Install the Left and Right Rear Corner Belt Rails on each side of the vehicle. Use the Corner Belt Rails as templates to mark, center punch and drill two 3/8" holes in the top edge of the vehicle body. Install the Corner Belt Rails with two 5/16" Phillips Head Bolts, two 5/16" Washers and two 5/16" Tapping Plates. At the location of the remaining hole in the Corner Belt Rail, next to the tailgate, mark, center punch and drill a 1/8" hole. Install a #8 x 1/2" Pan Head Screw. **Do not tighten the bolts yet.**

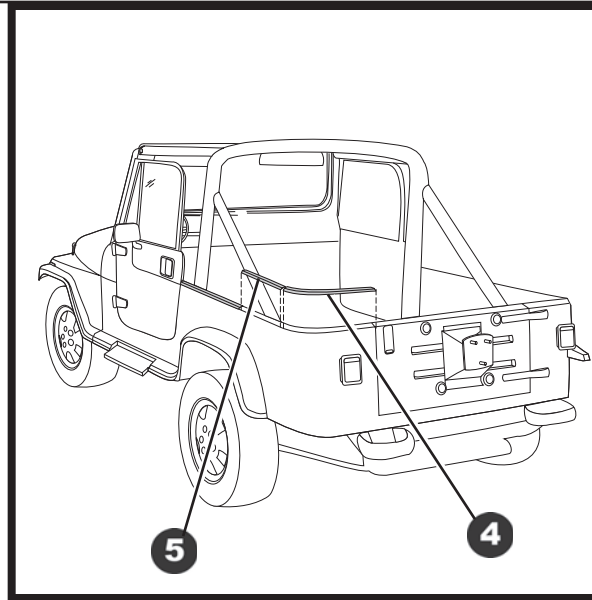

CAUTION

When drilling in the top edge of the vehicle body, check underneath for wiring for the rear lights. Pull the wiring out of the way before drilling.



5 Install Rear Side Belt Rails

Set the Rear Side Belt Rails on the side of the body between the Front Side Belt Rails and the Rear Corner Belt Rails. Place each rail so that it is centered between the Front Side Belt Rail and the Rear Corner Belt Rail. Use the rail as a template to mark the two hole locations. Center punch and drill two (2) 3/8" holes on the top surface of the body. Install each Rear Side Belt Rail with two (2) 5/16" Phillips Head Bolts, two (2) 5/16" Washers and two (2) 5/16" Tapping Plates.

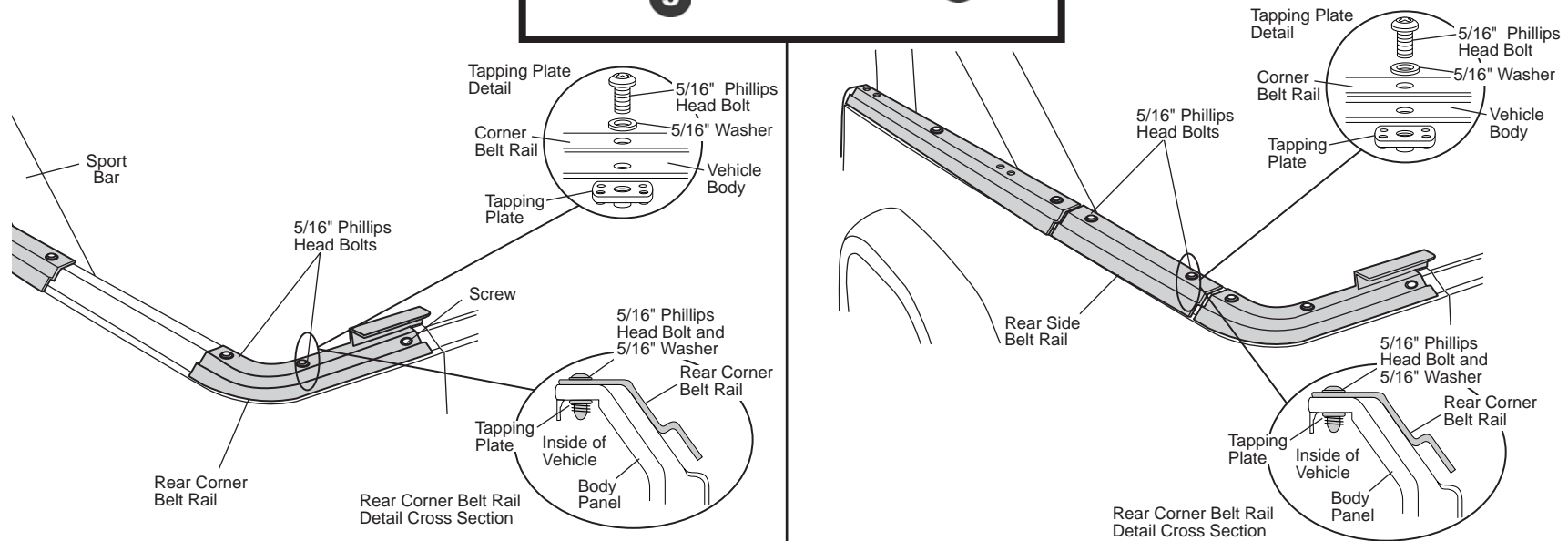

Supertop® – Installation Instructions

6 Install Vertical Retainer Mounts

Install the Vertical Retainer Mounts on top of the Side Belt Rails, just behind the door openings. Secure them in place with two 5/16-18 x 1" Phillips Head Bolts, two 5/16" Washers and two 5/16" Tapping Plates.

Tighten all the bolts on the Belt Rails.

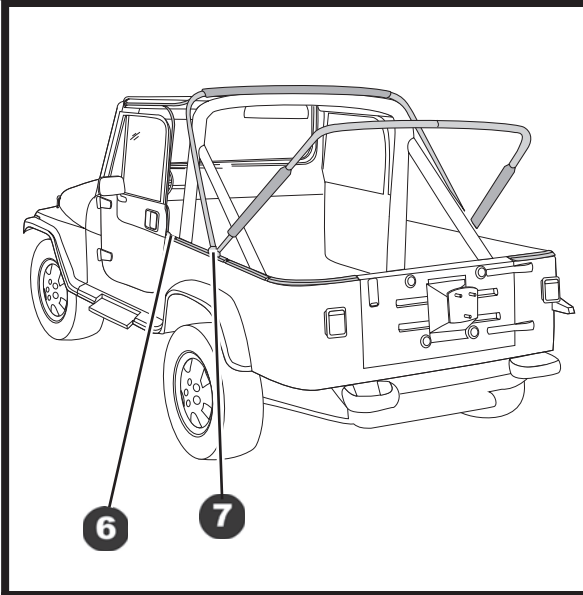
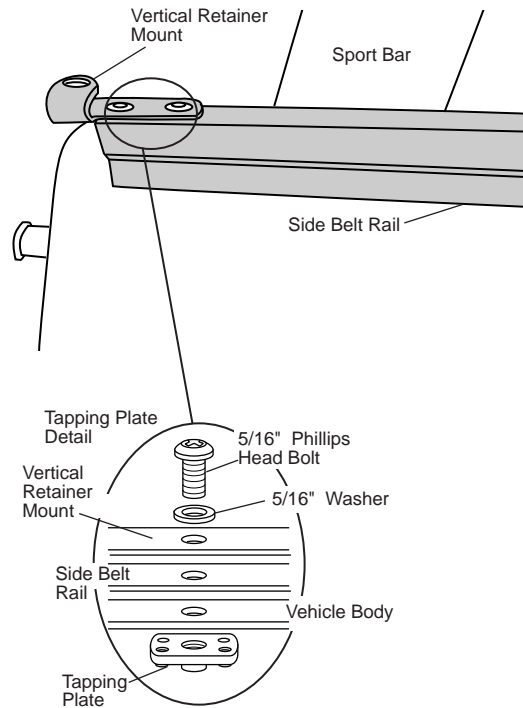

7 Install Bow Assembly

Drill a 5/32" hole in the center of each of the 1/4" holes in the Front Side Belt Rails. Place a Bow Mount Bracket over each set of holes so the tall end of the bracket is toward the front. Use two (2) #10 x 1/2" Tapping Screws from the Bow Mount Kit to install each Bow Mount Bracket.

Use a Clevis Pin and Hairpin Keeper to install one leg of the Rear Bow into the front one of the three holes grouped at the rear of the Bow Mount Bracket. Then use a Clevis Pin and Hairpin Keeper to install one leg of the Front Bow to the top front hole of the Bow Mount Bracket. Repeat this with the Bows on the other side of the vehicle.

Start the male end of the Left Front Bow into the female end of the Right Front Bow. Push forward on the bow until the two ends are fully engaged. Repeat on the Rear Bow.

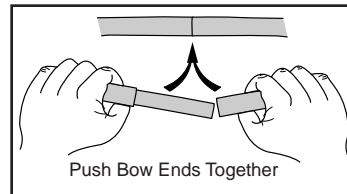
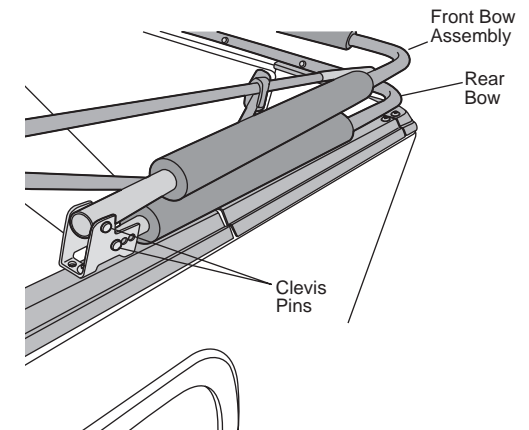
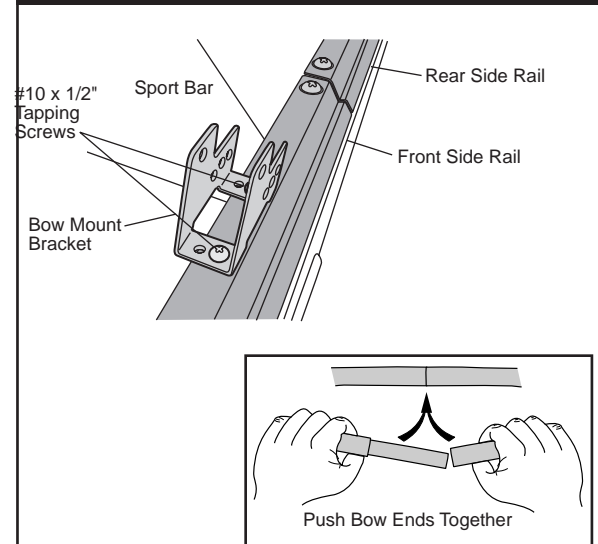

Supertop® – Installation Instructions

8 Secure Bow Assembly

Raise the Top (Front) Bow Assembly, holding the small rods in an upright position, and insert the Vertical Rods into the hole in the Vertical Retainer Mount. Attach the Horizontal Rod to the Windshield Bracket using the Bailhead Stud. The pin on the Bailhead Stud will only turn clockwise because of the prongs on the edges of the opening in the Windshield Bracket. Slip the pin through the opening and turn the Bailhead Stud a quarter turn clockwise so that the flanges on the pin are secure between the prongs.

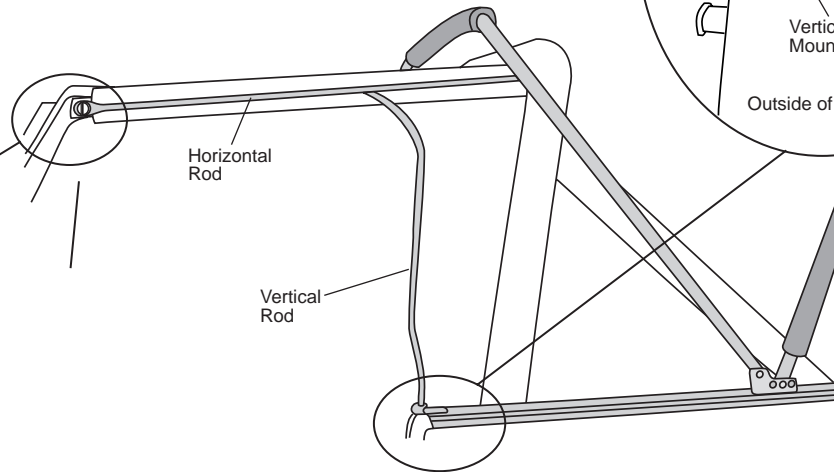
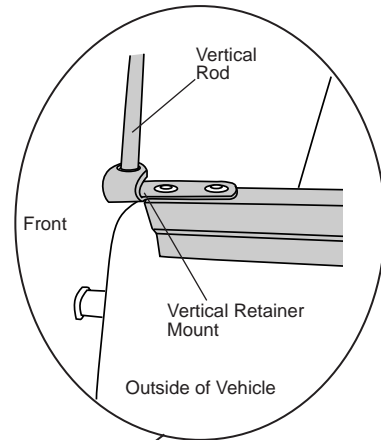
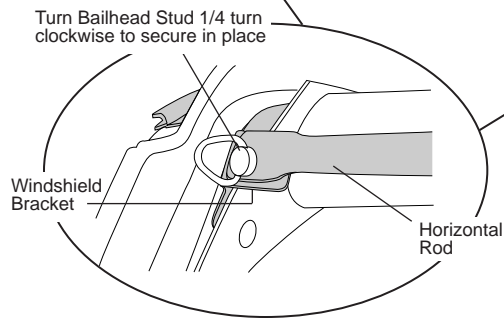
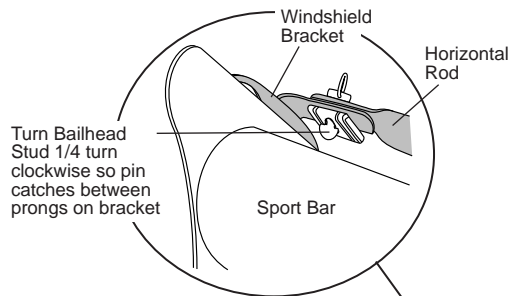
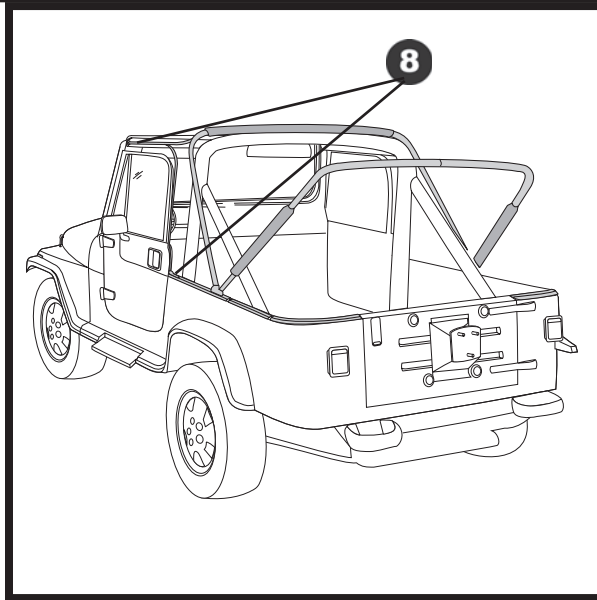

Supertop® – Installation Instructions

9 Install Top on Vehicle

Locate the top and orient it on the vehicle. Drape the top over the bows and insert the plastic strip sewn along the front of the top into windshield retainer attached on the front of the windshield frame. Center the front of the deck on the vehicle so that it is an equal distance from the top of the windshield flange on both sides.

NOTE For best possible installation, check to make sure that the soft top is perfectly centered on the vehicle.

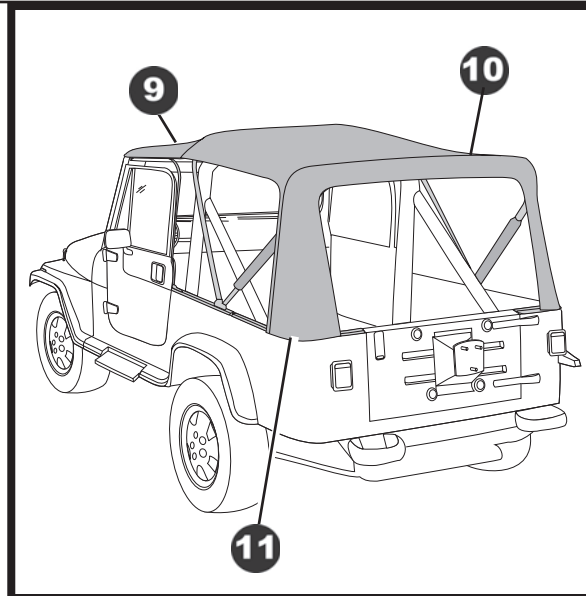
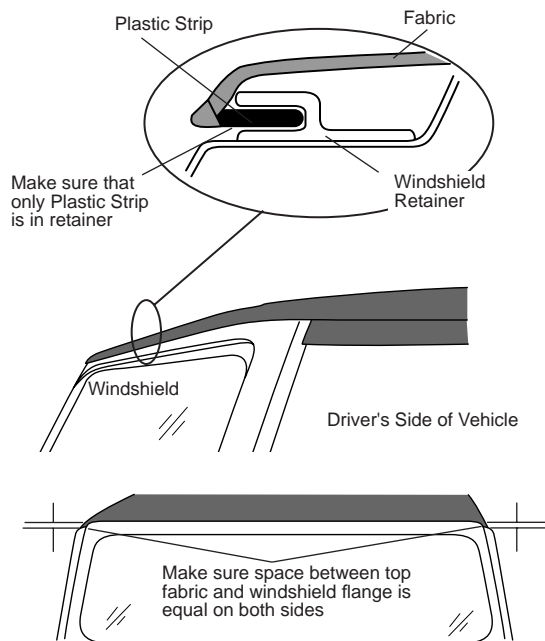

10 Snap Top to Rear Bow

Snap the flaps to the six studs on the rear bow.

NOTE If the snaps don't appear to line up, push the rear bow forward to relieve the pressure on the bow. This will allow the snaps to line up more easily.

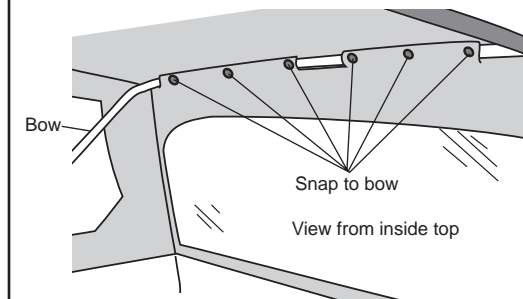

11 Secure Rear Corners

Insert the curved plastic strips at rear corners of top into Corner Belt Rails. There is a plastic reinforcement sewn into the corner of the top, in addition to the plastic strip.

Make sure that the reinforcement is not caught under the Corner Belt Rail.

Insert the straight plastic strip into the Rear Side Belt Rail.

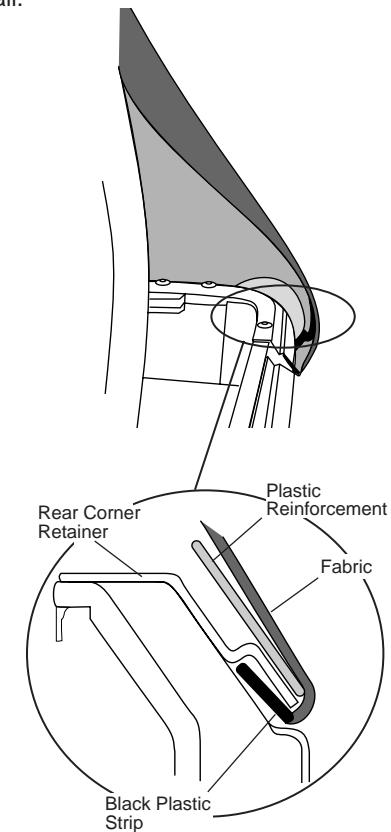

Supertop® – Installation Instructions

12 Adjust Tension of Top

The top will be extremely tight when it is new, but will loosen up after use. To tighten the top, move the Rear Bow back to the next hole in the Bow Mount Bracket.

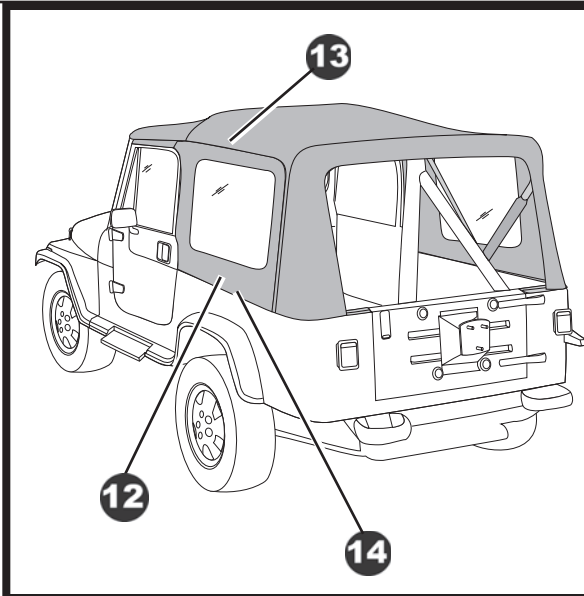
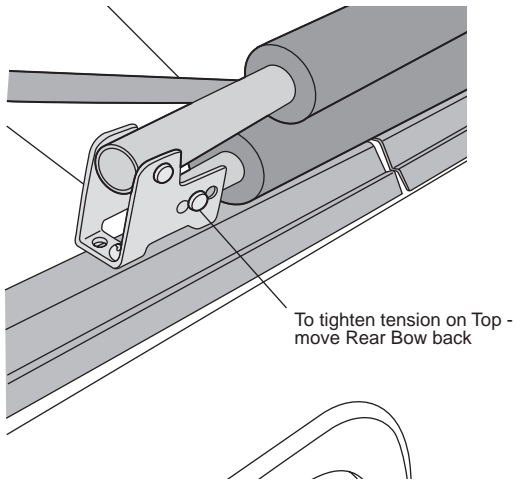

13 Install Side Curtain

Start top and rear zippers on side curtain 6 inches.

NOTE If necessary, release the Bow Coupler and slide the top around the Corner Belt Rail towards the window to make it easier to start the zippers on the Side Curtains.

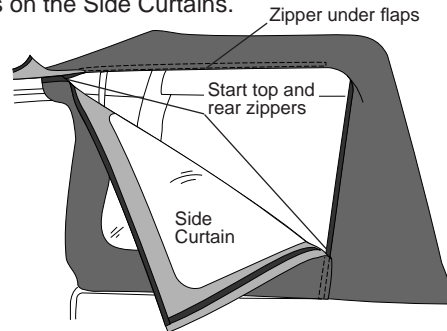

14 Secure Bottom of Side Curtain

Slip the plastic strip on the bottom of the side curtain into the side retainer. Close the top zipper on the side curtain.

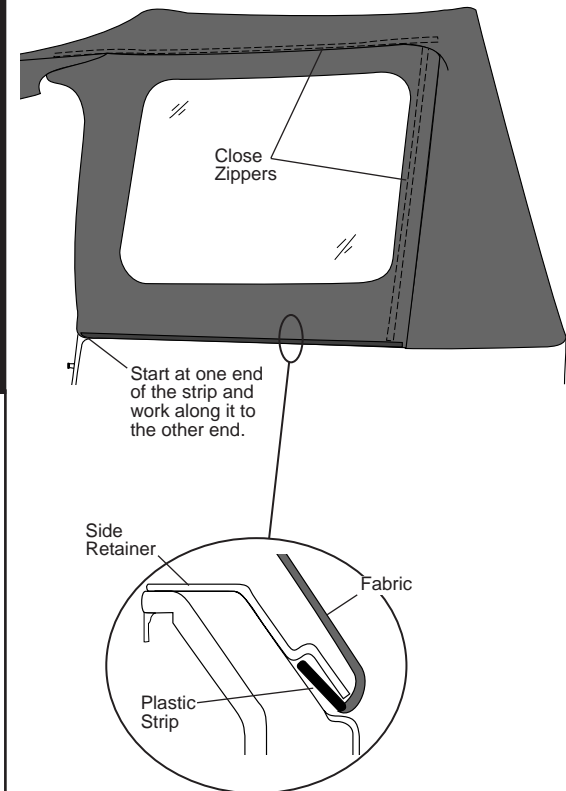

Supertop® – Installation Instructions

15 Secure Front of Side Curtain

Wrap fabric flap on the front of the side curtain around the Vertical Rod (not the front bow) and fasten the hook and loop strips to each other.

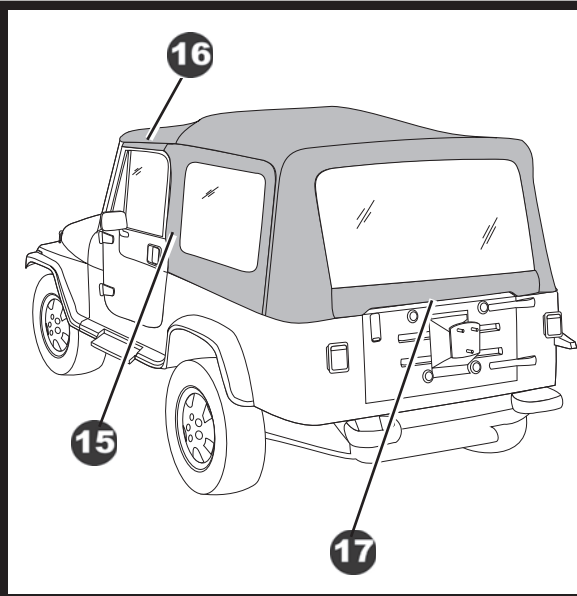
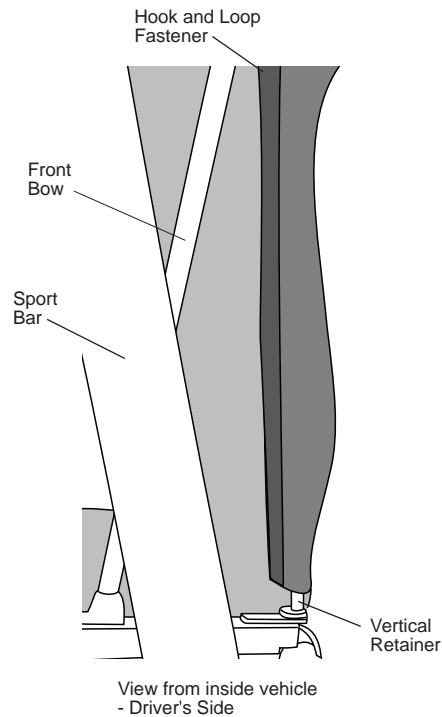

16 Secure Door Flaps

Wrap the flap, sewn to the top above each door, around the Horizontal Rod and fasten the hook and loop strips to each other.

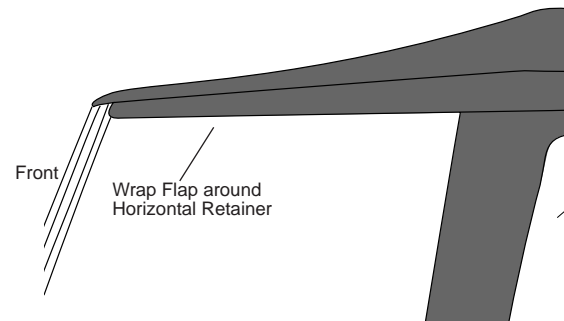

17 Install Rear Curtain Retainer

Open the tailgate. Orient the Rear Curtain Retainer with the rubber bulb facing down, in order to form a seal with the top of the tailgate. Slide the groove in the Rear Curtain Retainer onto the tube inside the bottom of the Rear Curtain. Roll the Rear Curtain Retainer into the top of the Corner Belt Rail. Slip the plastic on the bottom of the corners under the bottom of the Corner Belt Rail. Close the rear curtain zippers.

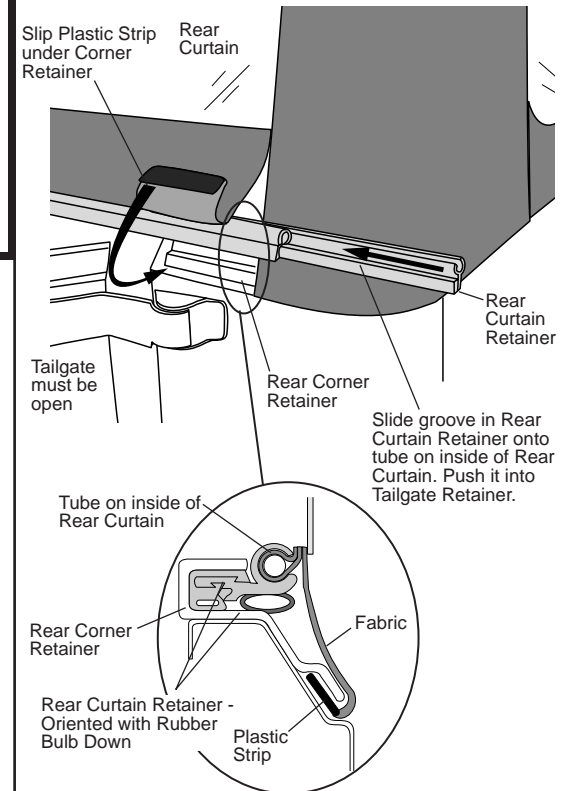

Supertop® – Installation Instructions

NOTE Now that your soft top is fully installed there are some final Metal Door adjustments that may need to be made to give you the best weather seal possible.

! WARNING If any of these adjustments are made, make sure that each area has been retightened. Each area should be rechecked within a week to assure proper fit and function.

18 Adjusting Vertical Retainer

The Vertical Retainer mount may be loosened and moved either forward or to the rear of the vehicle to tighten the seal or to allow more clearance.

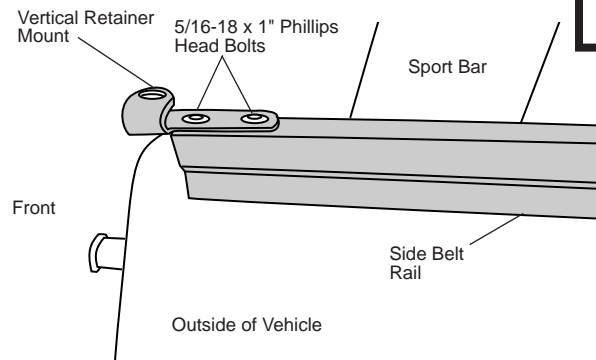
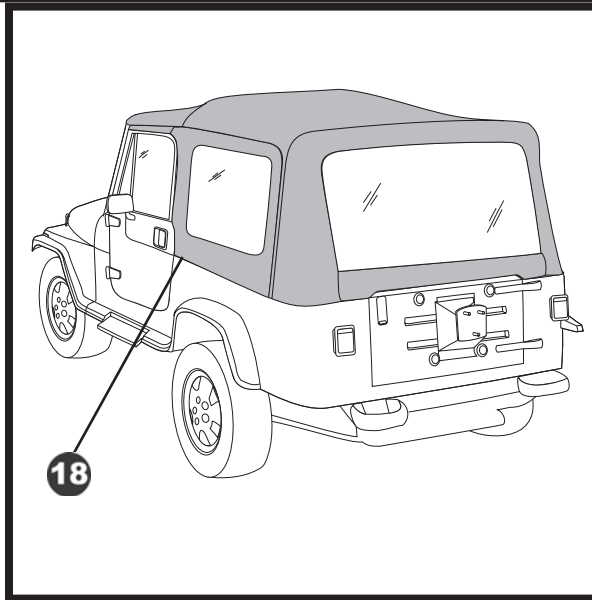

Supertop® – Installation Instructions



WARNING

When operating the vehicle without the Side Curtains, the Rear Curtain should be rolled up for proper ventilation.

19 Adjusting the Top

Side Curtains

To remove the Side Curtains. Unzip the rear and top zippers. Release the plastic strip from the retainer. Release the Hook and Loop Fasteners from around the Vertical Retainer.

Rear Curtain

To roll up the Rear Curtain, remove the Rear Curtain Retainer and start at the bottom, rolling it to the inside. Avoid wrinkles in the fabric and window. Secure it in place with the curtain straps inside of the top.

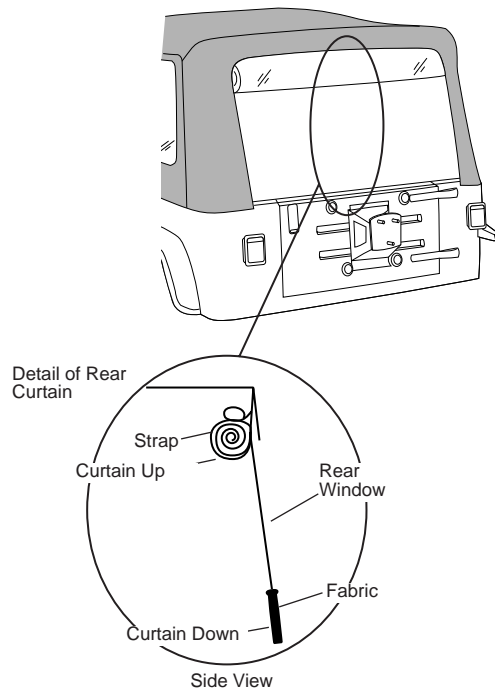

20 Folding the Top Down

Open the zippers at the rear of the Side Curtains. Pull the plastic strip on the bottom of the Side Curtains out of the Belt Rails. Leave the rear corners of the top attached to the Corner Belt Rails. Unfasten the hook and loop strips at the front of the Side Curtains, releasing the Side Curtains from the Vertical Retainer. Fold the Side Curtains up onto the top and release the hook and loop fasteners on the flaps, above the doors. Unsnap the top from the rear bow.

Release the locking tabs on the Bow Releases from the holes in the bow and slide the rear bow down to the Bow Mounts. Release the Horizontal Rod from the Windshield Bracket. Remove the Vertical Rod from the Vertical Retainer Mount and lay the bow assembly down on the rear of the vehicle.

Unfasten the top from the windshield and lay it down on the body. Make sure that the rear corners of the top are tucked under the rear bow. Fold the top in half from front to back and continue folding until the top is about 1 foot wide at the rear of the vehicle. Secure the top by clipping the Bow Tie Downs into the Side Belt Rails.

21 Removal of Soft Top for Open Air Driving

When operating the vehicle with the fabric top removed, it is very important that the supporting hardware system be disconnected from the windshield bracket and folded flat to the rear of the vehicle. Wrap the elastic straps around the bows and insert the plastic strip into the side belt rail. Never operate the vehicle with the fabric removed and the hardware in the fully erected position.

Supertop® – Installation Instructions

Care and Maintenance of your Bestop Product

Your Bestop product is made of the finest materials available. To keep it looking new and for the maximum possible wear, it will need periodic cleaning and maintenance.

Washing: The fabric should be washed often using soap, warm water and a soft bristle brush. Rinse with clear water to remove all traces of soap or use Bestop-recommended Bestop Cleaner and Bestop Protectant. Bestop Cleaner and Bestop Protectant are specially formulated to provide a total cleaning and protection system. Bestop Cleaner will not harm vehicle finish, is biodegradable and environmentally friendly. Bestop Protectant protects against UV-fading, cracking and hardening.

Windows: Keep windows clean to avoid scratching. DO NOT use a brush on the windows! Wash with a water-soaked cloth or sponge and a mild dishwashing detergent or use Bestop-recommended Bestop Vinyl Window Cleaner, which safely cleans and protects vinyl windows while helping prevent UV damage. NEVER WIPE THE WINDOWS WHEN THEY ARE DRY. Be careful when cleaning snow or frost from the vinyl windows since they are easily scratched and may crack at low temperatures. DO NOT roll the sides or rear window in cold weather. The windows become stiff and will crack.

Zippers: Keeping the zipper cleaned and lubricated with a silicone lubricant will help prevent damage and keep the zippers in a smooth working condition. If a zipper opens behind the slider, the slider may have been spread apart. This problem can usually be repaired by using an ordinary pair of pliers to bring the sides back into parallel. Return slider to the end of the zipper in the normal Open position. Squeeze lightly at first and test the zipper. If the zipper continues to remain open squeeze more firmly with the pliers and try the zipper again. Repeat this procedure until the zipper operates correctly.

Water: Seeping through at the seams may be stopped by applying 3-M Scotchgard® on the inside of the seams. Rips in the fabric may be repaired with Bondex® iron on patches. Iron the patches to the Inside of the top, carefully following the Bondex® instructions.

Snaps: Keep snaps cleaned and lubricated with silicone to help prevent snaps from sticking to the studs. If a snap does become stuck to a stud, use a screwdriver and GENTLY pry apart to prevent permanent damage to the snap or the top fabric.

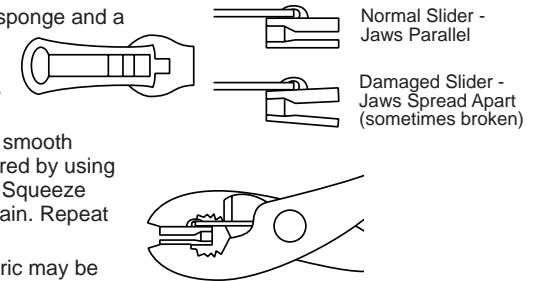

LIMITED WARRANTY

We warrant our product to be free from defects in material and workmanship, for the terms specified below, provided there has been normal use and proper maintenance. This warranty applies to the original purchaser only. All remedies under this warranty are limited to the repair or replacement of any item or items found by the factory to be defective within the time period specified. If you have a warranty claim, first you must call our factory at the number below for instructions. You must retain proof of purchase and submit a copy with any items returned for warranty work. Upon completion of warranty work, if any, we will return the repaired or replaced item or items to you freight prepaid. Damage to our products caused by accidents, fire, vandalism, negligence, misinstallation, misuse, Acts of God, or by defective parts not manufactured by us, is not covered under this warranty.

THE WARRANTY TIME PERIOD IS AS FOLLOWS FOR REPLACE-A-TOP™, SAILCLOTH REPLACE-A-TOP™, SUPERTOP®, SUPERTOP® REPLACEMENT SKINS, SUNRIDER®, AND TIGERTOP®: TWO YEARS FROM DATE OF PURCHASE.

THE WARRANTY TIME PERIOD IS AS FOLLOWS FOR ALL OTHER "SOFT GOODS" MANUFACTURED BY OUR COMPANY (USING PRIMARILY VINYL, PLASTICS, AND/OR FOAM): ONE YEAR FROM DATE OF PURCHASE.

THE WARRANTY TIME PERIOD IS AS FOLLOWS FOR ALL OTHER "HARD GOODS" MANUFACTURED BY OUR COMPANY (USING PRIMARILY METALS, PLASTICS, AND/OR FIBERGLASS): ONE YEAR FROM DATE OF PURCHASE.

ANY IMPLIED WARRANTIES OF MERCHANTABILITY AND/OR FITNESS FOR A PARTICULAR PURPOSE CREATED HEREBY ARE LIMITED IN DURATION TO THE SAME DURATION AND SCOPE AS THE EXPRESS WRITTEN WARRANTY. OUR COMPANY SHALL NOT BE LIABLE FOR ANY INCIDENTAL OR CONSEQUENTIAL DAMAGE.

Some states do not allow limitations on how long an implied warranty lasts, or the exclusion or limitation of incidental or consequential damages, so the above limitations or exclusions may not apply to you. This warranty gives you specific legal rights, and you may also have other rights which vary from state to state.



For further information or request for warranty work, please contact:

Bestop Inc., Customer Service
Toll-Free: (800)845-3567
Main: (303)465-1755
E-mail: csbestop@Bestop.com
Website: www.Bestop.com