



# Installation Instructions Sunrider for Hardtop

Vehicle Application:  
Ford Bronco 2 Door 2021-Current  
Part Number 52460

## Installation Tips

Before you begin installing your new Sunrider for Hardtop, please read all the instructions thoroughly, and watch the Bestop Installation video. (See Support section on this page).

For easier installation, the top should be installed at a temperature above 72° F. Below this temperature, the fabric may contract making it difficult to fit the vehicle.







**WARNING** Do not rely in any way on the components of this product to protect against injury or death in the event of an accident. Never operate the vehicle in excess of manufacturer's specifications.

Read and follow, precisely, all installation instructions provided when installing this product. Failure to do so may result in a poor fit and could place occupants of the vehicle in a potentially dangerous situation.



**CAUTION** Safety glasses should be worn at all times when installing this product.

**WEAR SEAT BELTS AT ALL TIMES**

Tools			Installation Time		Support
 Safety Glasses	 4mm Hex Key	 T30, T40 and T50 Torx Drivers	 30 minutes	We're here to help! Go to: <a href="https://www.bestop.com">https://www.bestop.com</a> and click on Need Help?	
			Skill Level		
			 1 - Easy		
					<a href="https://www.bestop.com/video-library">https://www.bestop.com/video-library</a>



# Installation Instructions Sunrider for Hardtop

Vehicle Application:  
Ford Bronco 2 Door 2021-Current  
Part Number 52460

## Parts List

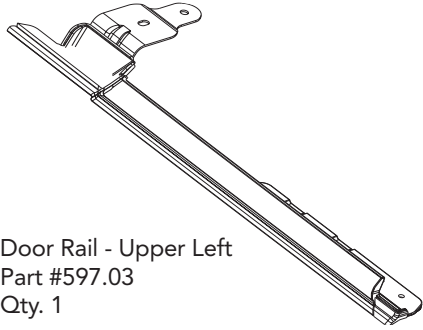

Door Rail - Upper Left  
Part #597.03  
Qty. 1

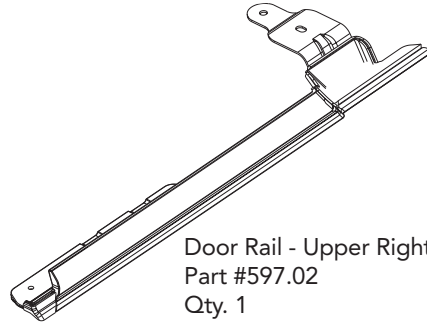

Door Rail - Upper Right  
Part #597.02  
Qty. 1

Shown without fabric

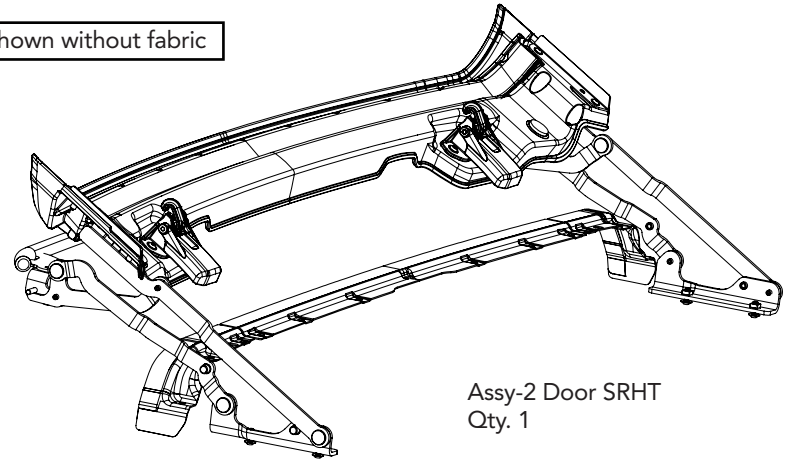

Assy-2 Door SRHT  
Qty. 1



Nut, M6-1.0  
Part #515.82  
Qty. 4

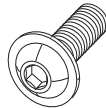

Screw, M6 X 1.00 X 20  
Part #517.48  
Qty. 6

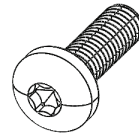

Screw, M8 X 1.25 X 25  
Part #598.93  
Qty. 2

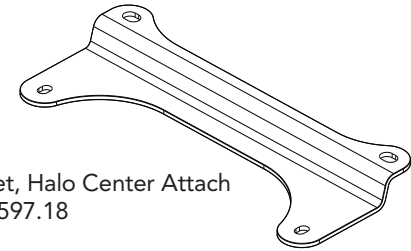

Bracket, Halo Center Attach  
Part #597.18  
Qty. 1

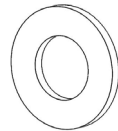

M8 Washer Black  
Part #603.26  
Qty. 4

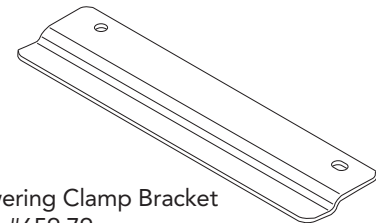

Lowering Clamp Bracket  
Part #659.79  
Qty. 2

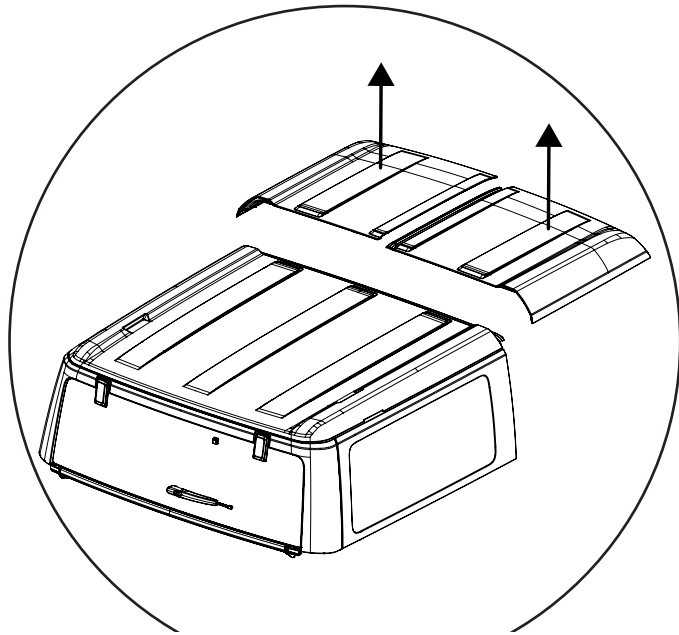

Remove the hardtop panels.  
(See owners manual for details)

**Note:** Roof rack (If Equipped) Must Be Removed for soft top operation

Remove

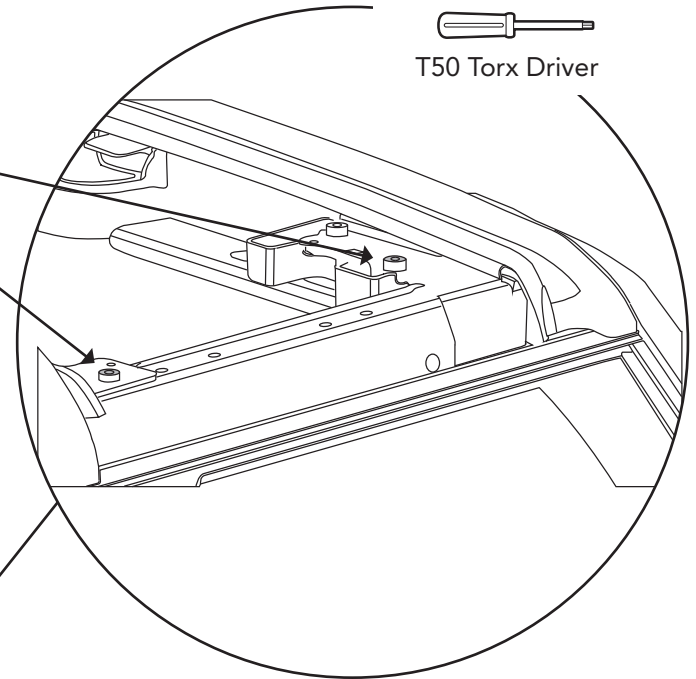

T50 Torx Driver

Remove the bolts from the vehicle (two from each side) and hold onto them.

**Note:** These bolts will be reused later in the installation.

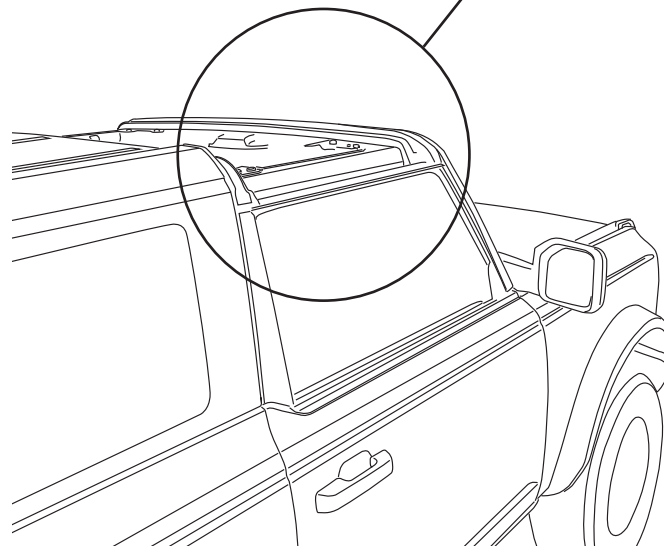

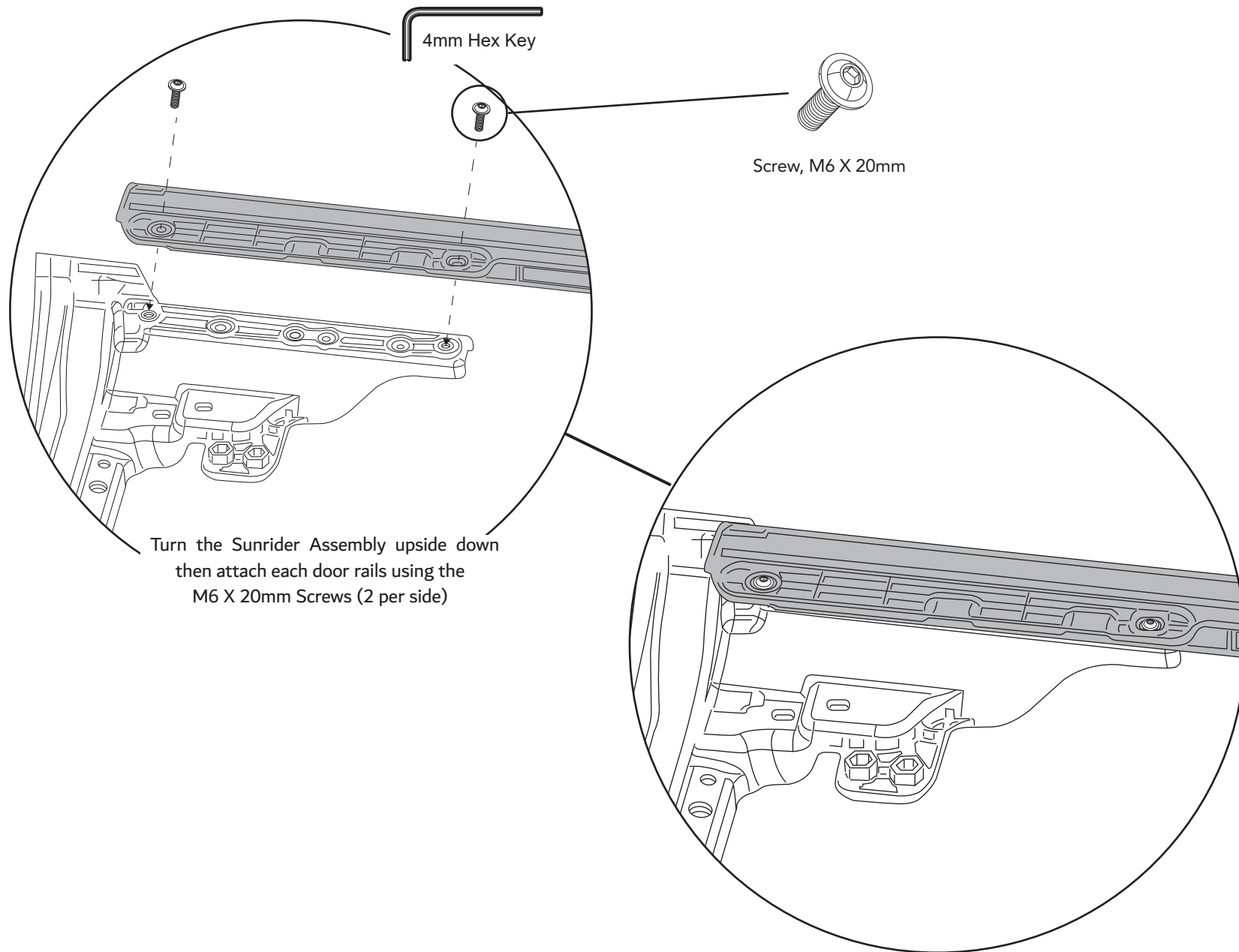

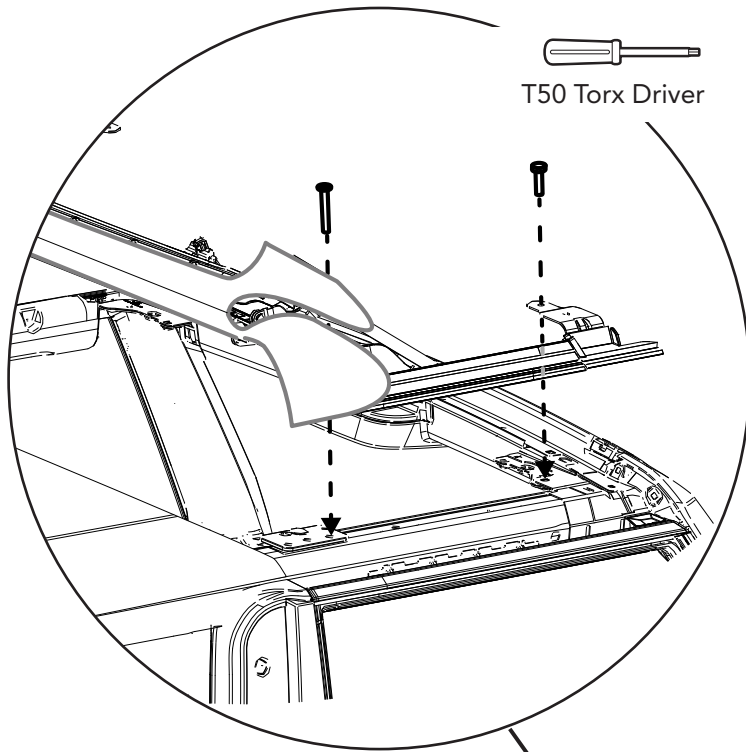

T50 Torx Driver

Turn the Sunrider assembly over then place it on the vehicle. Use the fasteners that were removed in section 1 to attach the Sunrider to the vehicle.

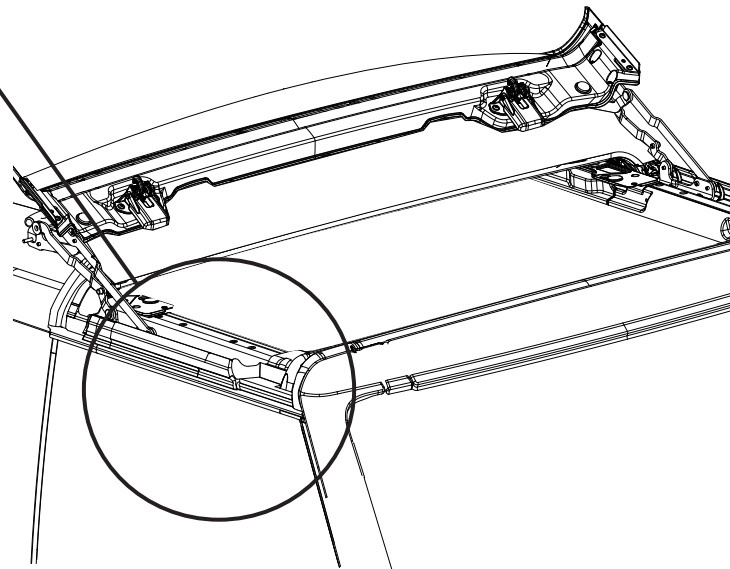

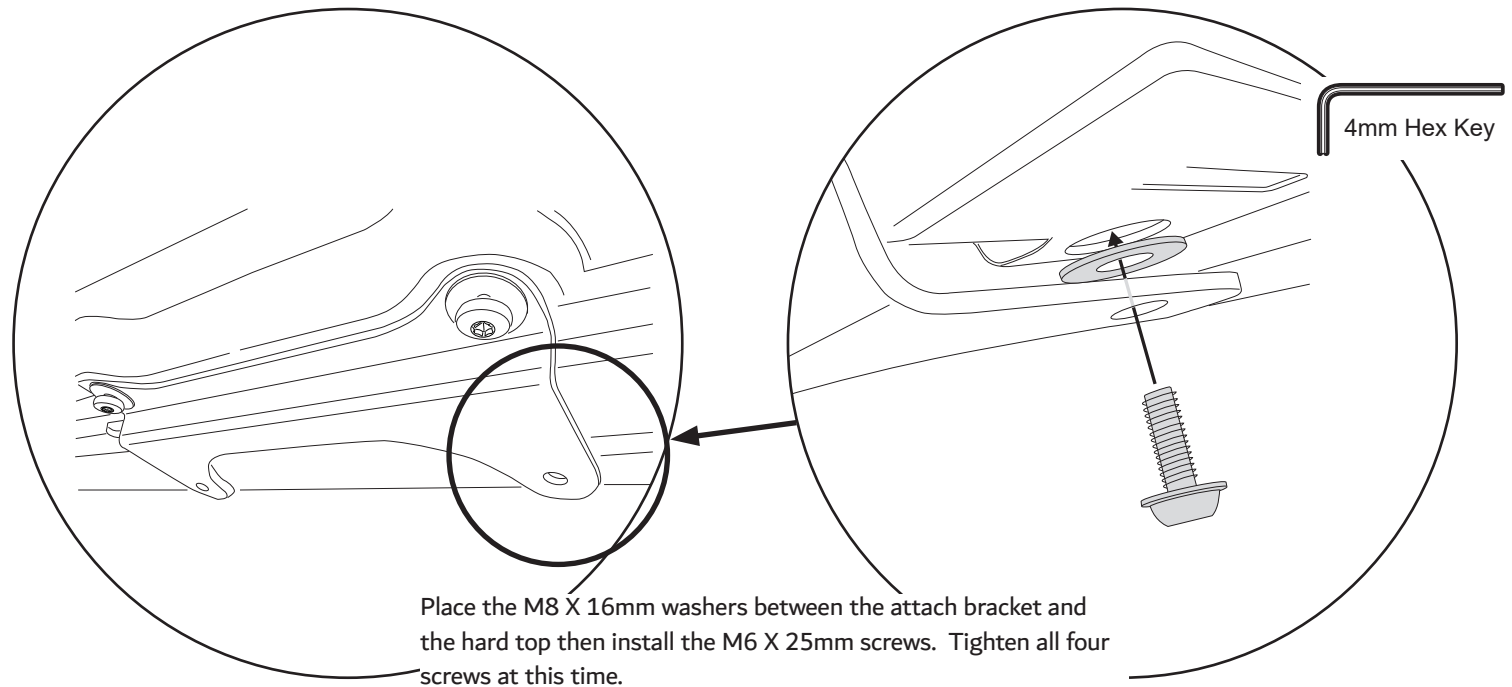
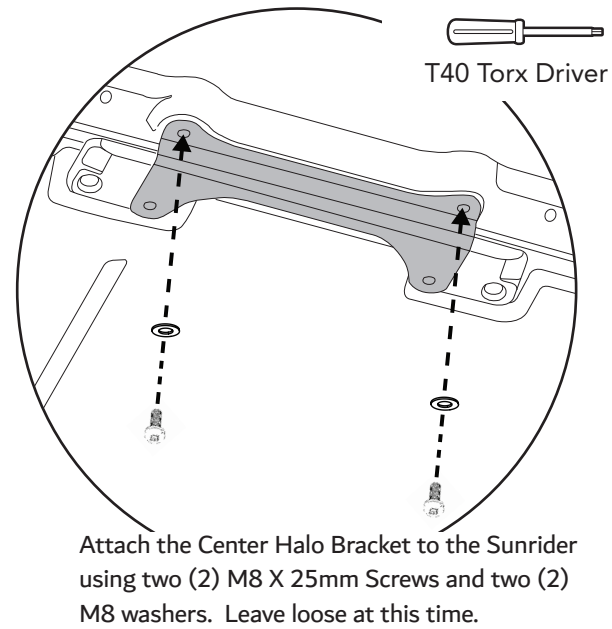
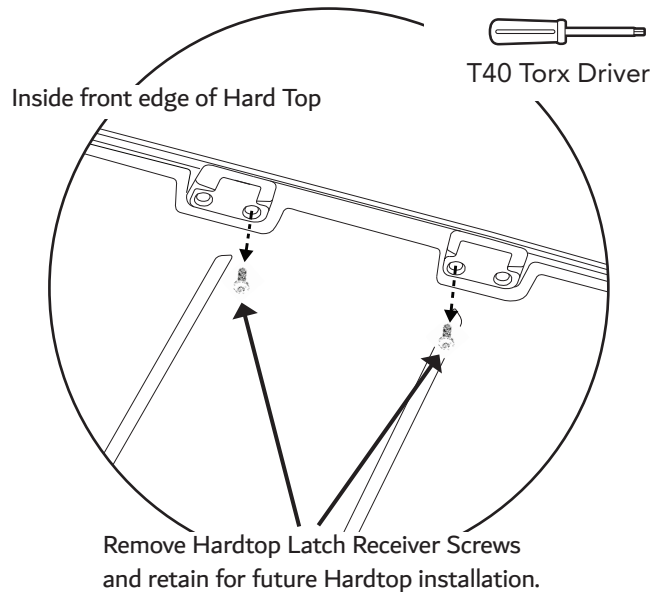

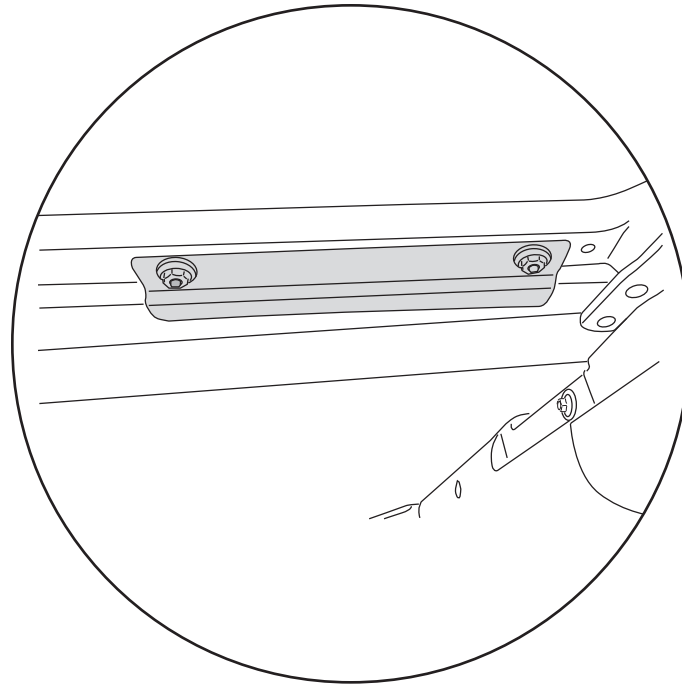
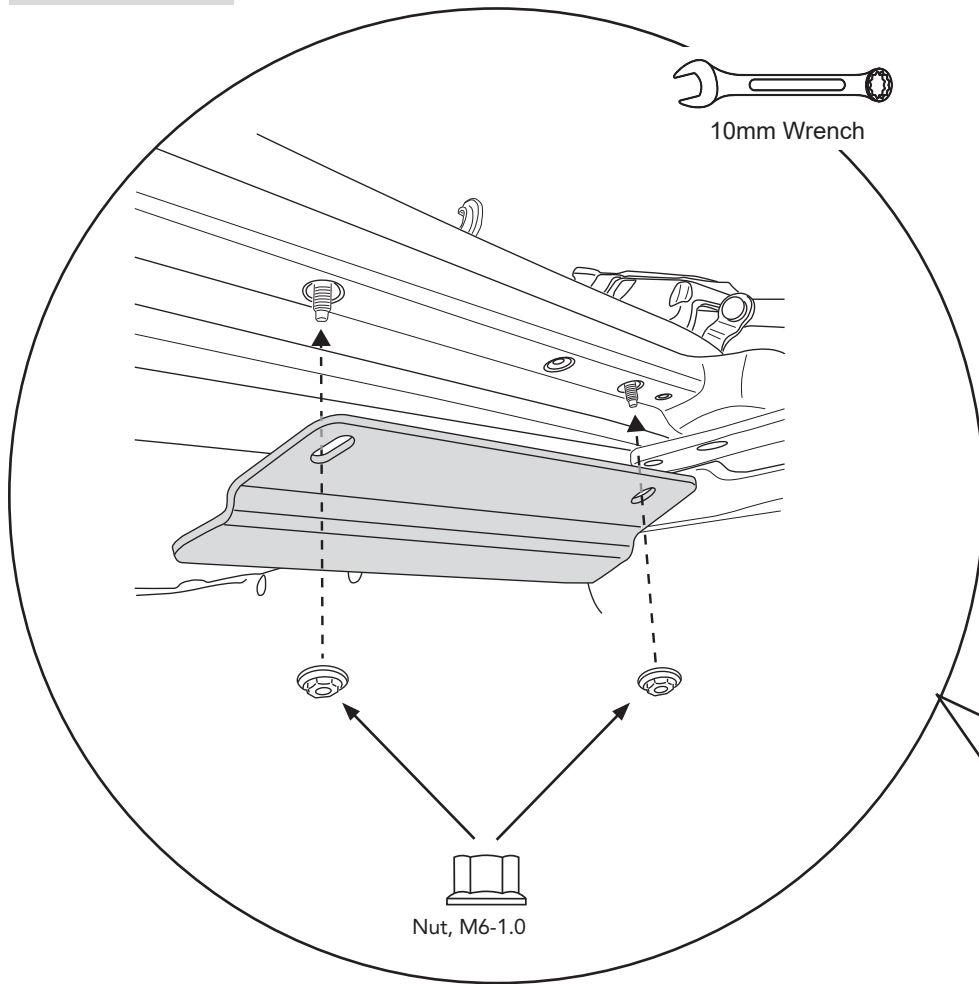

Place the Lowering Clamp Bracket over the two protruding screws with the step going toward the edge of the hard top then place and tighten the M6 nuts. Repeat on the other side of the vehicle.

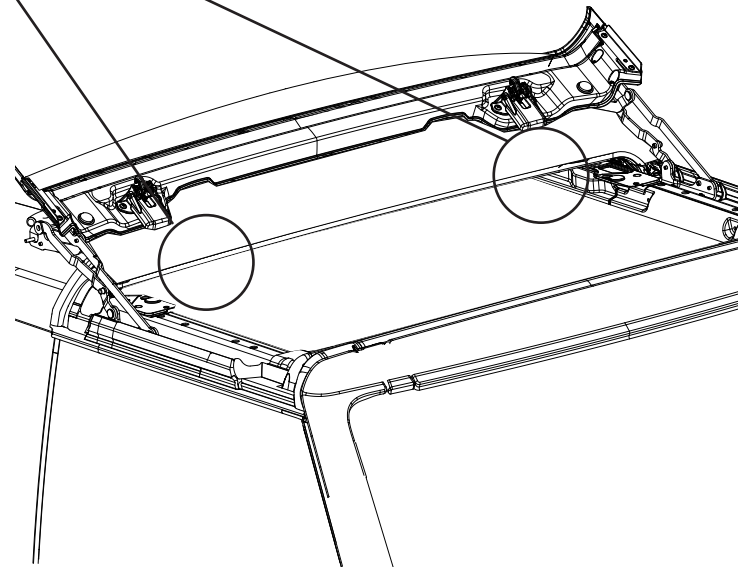

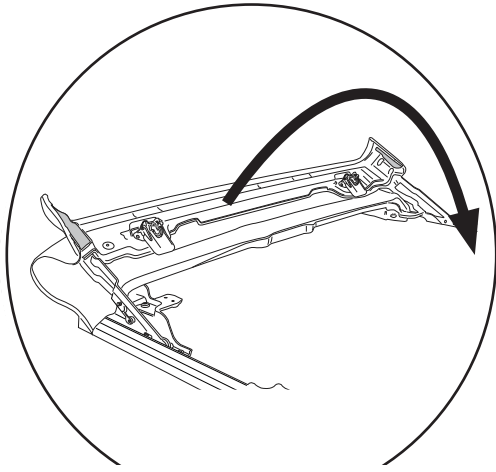

Fold the Sunrider forward.

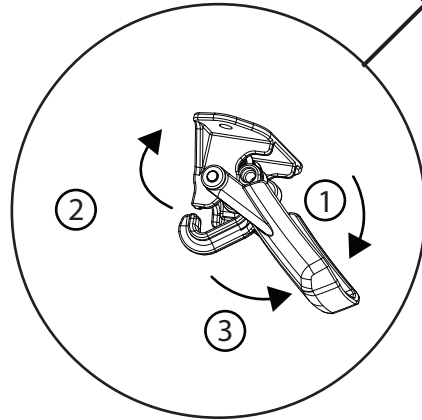
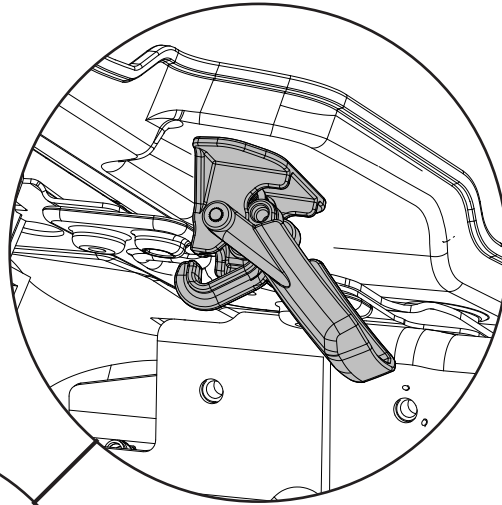

Secure both latches to the vehicle's windshield header.

- ① Pivot the latch handle down;
- ② Engage the hook;
- ③ Pivot the latch handle back up.

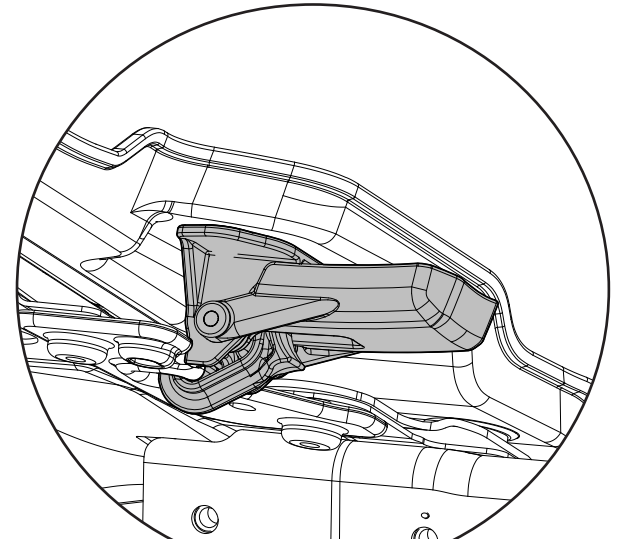

Latch in closed position





## Care and Maintenance of your Bestop Product

Your Bestop product is made of the finest materials available. To keep it looking new and for the maximum possible wear, it will need periodic cleaning and maintenance.

**Fabric:** The fabric should be washed often using soap, warm water and a soft bristle brush. Rinse with clear water to remove all traces of soap. Bestop recommends using Bestop Cleaner (part no. 11201-00) and Bestop Protectant (part no. 11202-00) for Vinyl fabric and Bestop Twill Protectant (part no. 11207-00) for Twill fabric. Bestop Cleaner and Bestop protectant are specially formulated to provide a total cleaning and protection system. Bestop Cleaner safely removes the toughest stains, will not harm vehicle finishes, is biodegradable and environmentally friendly. Bestop Protectant protects against UV-fading, cracking and hardening, and repels dust, grease, dirt and mildew.

**Windows:** Keep windows clean to avoid scratching. **DO NOT** use a brush on the windows! Wash with a water-soaked cloth or sponge and a mild dishwashing detergent. Bestop recommends Bestop Vinyl Window Cleaner (part no. 11203-00), which safely cleans and protects vinyl windows and helps prevent UV damage. **NEVER WIPE THE WINDOWS WHEN THEY ARE DRY.** Be careful when cleaning snow or frost from the vinyl windows since they are easily scratched and may crack at low temperatures. **DO NOT** roll the sides or rear window in cold weather. The windows become stiff and will crack. Cracks caused by misuse in cold temperatures are not covered under warranty.

**Water:** Seeping through at the seams may be stopped by applying 3-M Scotchgard® on the inside of the seams.

**Snaps:** Keep snaps cleaned and lubricated with silicone to help prevent snaps from sticking to the studs. If a snap does become stuck to a stud, use a screwdriver and **GENTLY** pry apart to prevent permanent damage to the snap or the top fabric.

**Zippers:** Keeping zippers cleaned and lubricated with Bestop's Zipper Cleaner (part no. 11206-00) will help prevent damage and keep the zippers in smooth working condition. If a zipper opens behind the slider, the slider may have been spread apart. This problem can usually be repaired by using an ordinary pair of pliers to bring the sides back into parallel. Return slider to the end of the zipper in the normal Open position. Squeeze lightly at first and test the zipper. If the zipper continues to remain open squeeze more firmly with the pliers and try the zipper again. Repeat this procedure until the zipper operates correctly.

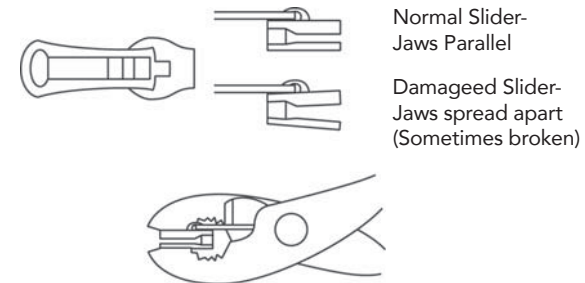

**For Bestop Warranty Information, Please go to;**  
<https://www.bestop.com/help/warranty-information/>





# Instrucciones para la instalación del Sunrider para techo rígido

Aplicación del vehículo:  
Ford Bronco 2 puertas 2021-Actual  
Número de parte 52460

## Consejos para la instalación

Antes de empezar a instalar su nuevo Sunrider para techo rígido, lea todas las instrucciones detenidamente, y vea el video de Instalación de Bestop. (Ver la sección de Soporte en esta página).

Para facilitar la instalación, la cubierta se debe colocar a una temperatura por encima de 72 °F. Por debajo de esta temperatura, la tela puede contraerse dificultando el ajuste con el vehículo.











**ADVERTENCIA** No confíe en modo alguno en los componentes de este producto para protegerse de lesiones o muerte en caso de accidente. Nunca opere el vehículo excediendo las especificaciones del fabricante.

Al instalar este producto, lea y siga con precisión todas las instrucciones proporcionadas. De lo contrario, se puede producir un ajuste defectuoso y se podría colocar a los ocupantes del vehículo en una situación potencialmente peligrosa.



**PRECAUCIÓN** Se deben usar anteojos de seguridad en todo momento al instalar este producto.

**USE CINTURONES DE SEGURIDAD EN TODO MOMENTO**

Herramientas	Tiempo de instalación	Soporte
 <p>Anteojos de seguridad</p>  <p>Llave hexagonal de 4 mm</p>  <p>Destornilladores torx T30, T40 y T50</p>  <p>Llave de 10 mm</p>	 <p>30 minutos</p> <p>Nivel de destreza</p>     <p>1: Fácil</p>	<p>¡Estamos aquí para ayudar! Vaya a: <a href="https://www.bestop.com">https://www.bestop.com</a> y haga clic en ¿Necesita ayuda?</p>  <p><a href="https://www.bestop.com/video-library">https://www.bestop.com/video-library</a></p>



# Instrucciones para la instalación Sunrider para techo rígido

Aplicación del vehículo:  
Ford Bronco 2 puertas 2021 Actual  
Número de parte 52460

## Lista de partes

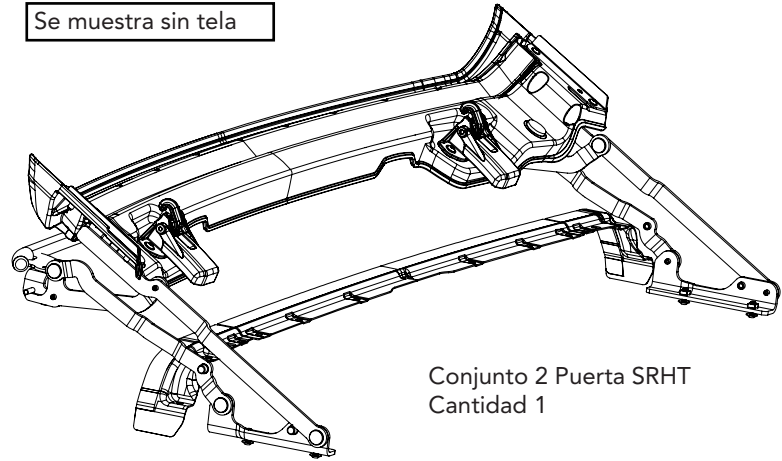
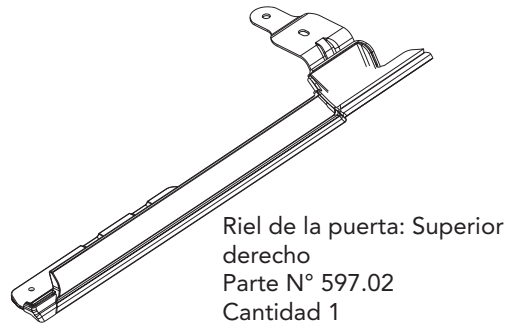
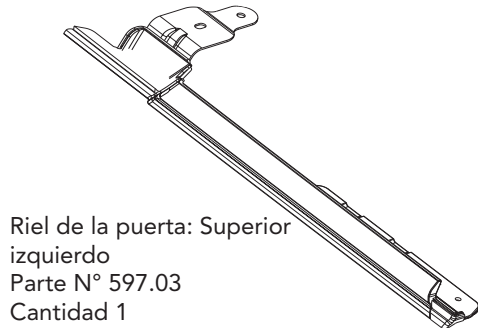

Tuerca, M6-1.0  
Pieza #515.82  
Cant. 4

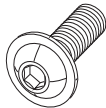

Tornillo, M6 X 20  
Parte N° 517.48  
Cant. 6

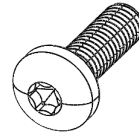

Tornillo M8 X 25  
Parte N° 598.93  
Cant. 2

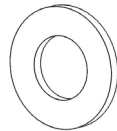

Arandela negra M8  
Parte N° 603.26  
Cant. 4

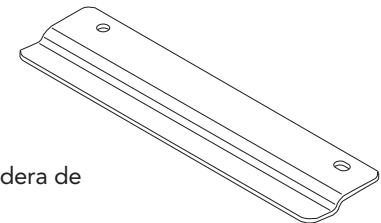
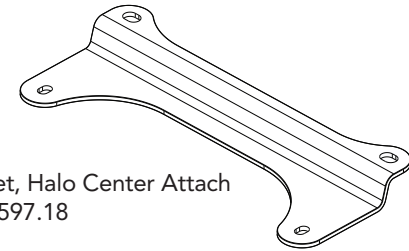

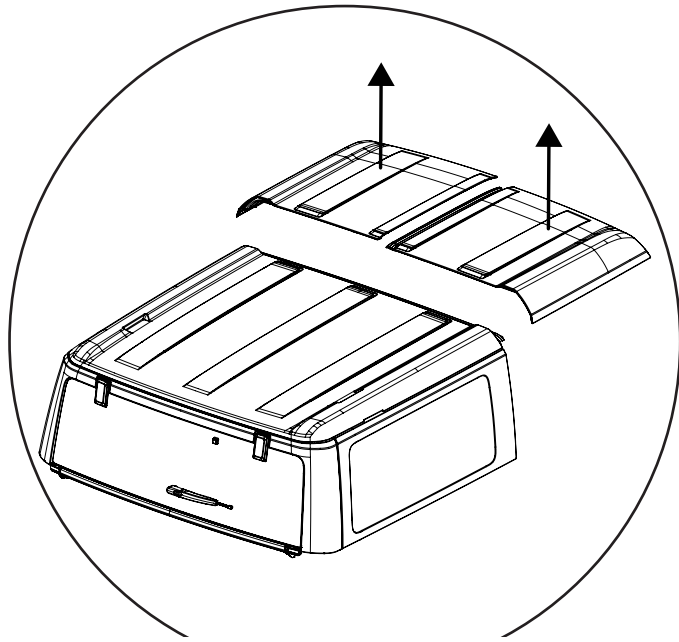

Quitar los paneles frontales del techo rígido. (Ver los manuales del propietario para los detalles)

**Nota:** El portaequipajes (si está equipado) debe ser retirado para el funcionamiento de la capota

Retirar

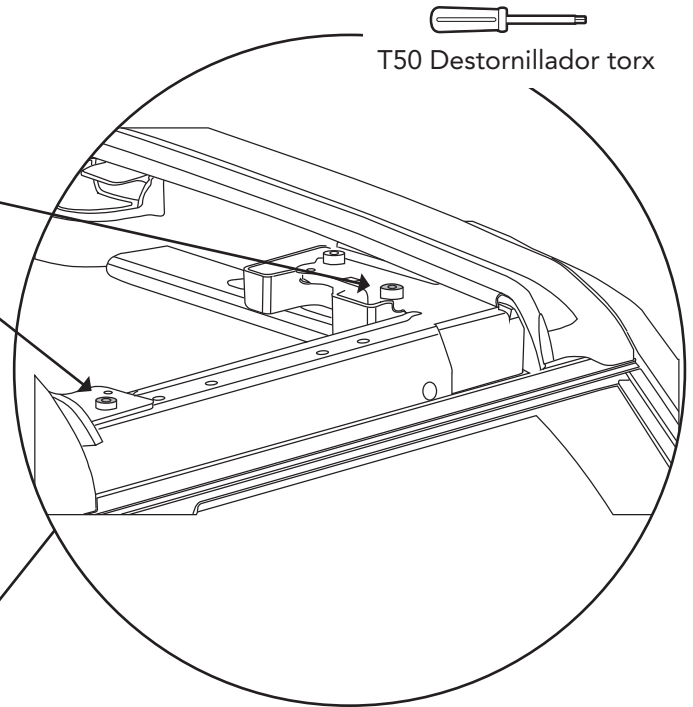

Quitar los pernos del vehículo (dos de cada lado) y conservarlos.

**Nota:** Estos pernos se volverán a usar más tarde en la instalación.

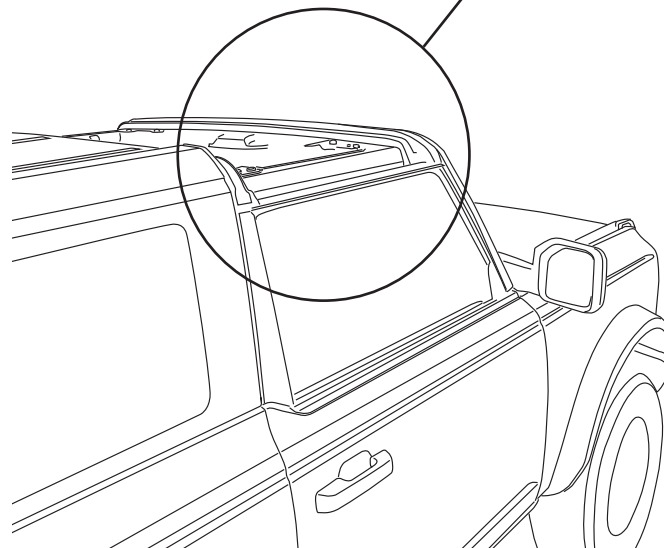

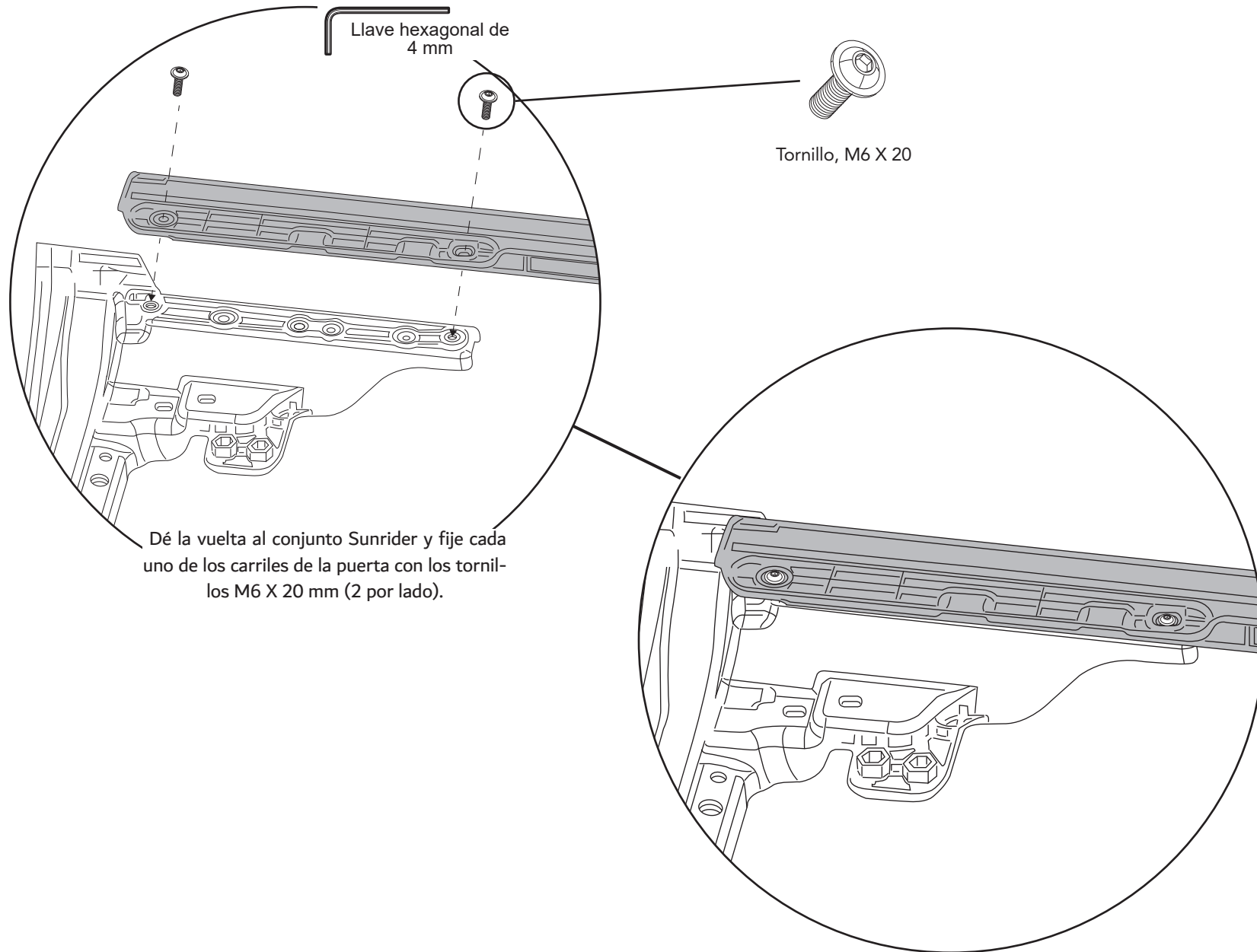

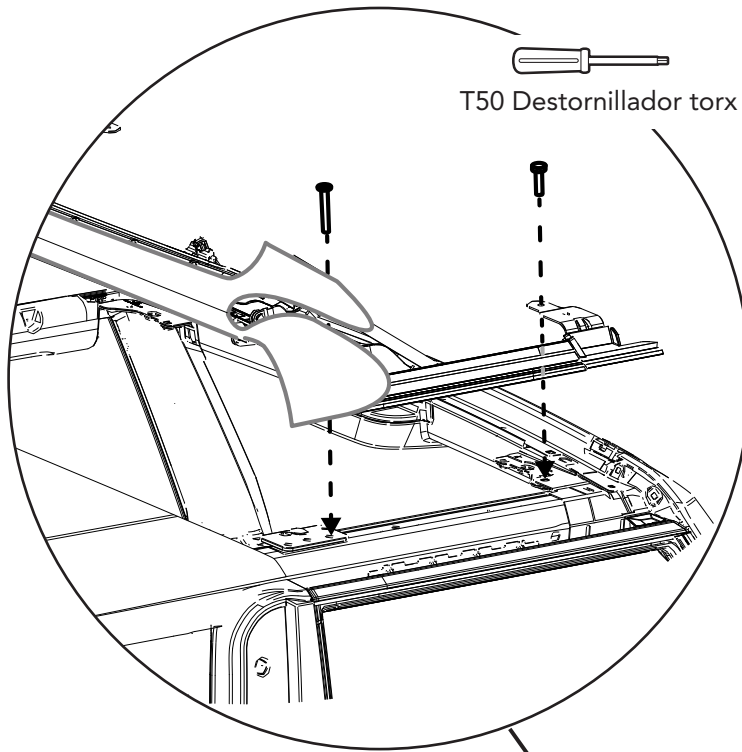

Dé la vuelta al conjunto Sunrider y colóquelo sobre el vehículo. Utilice los elementos de fijación que se retiraron en la sección 1 para fijar el Sunrider al vehículo.

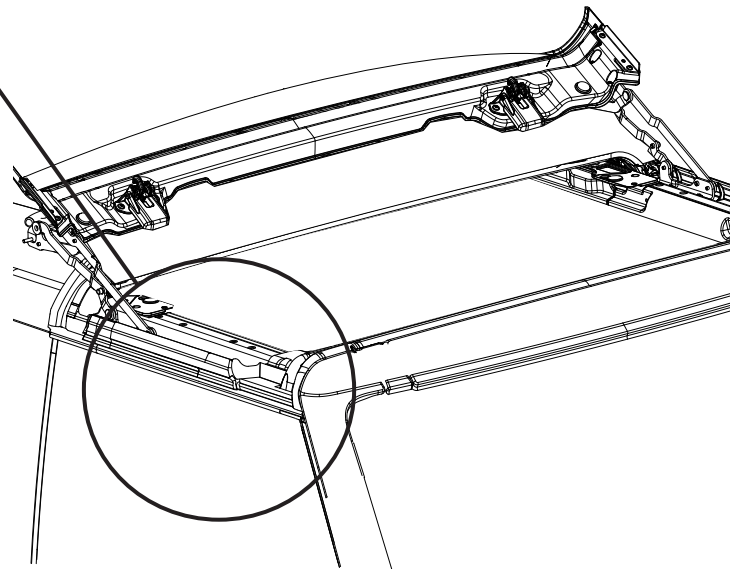

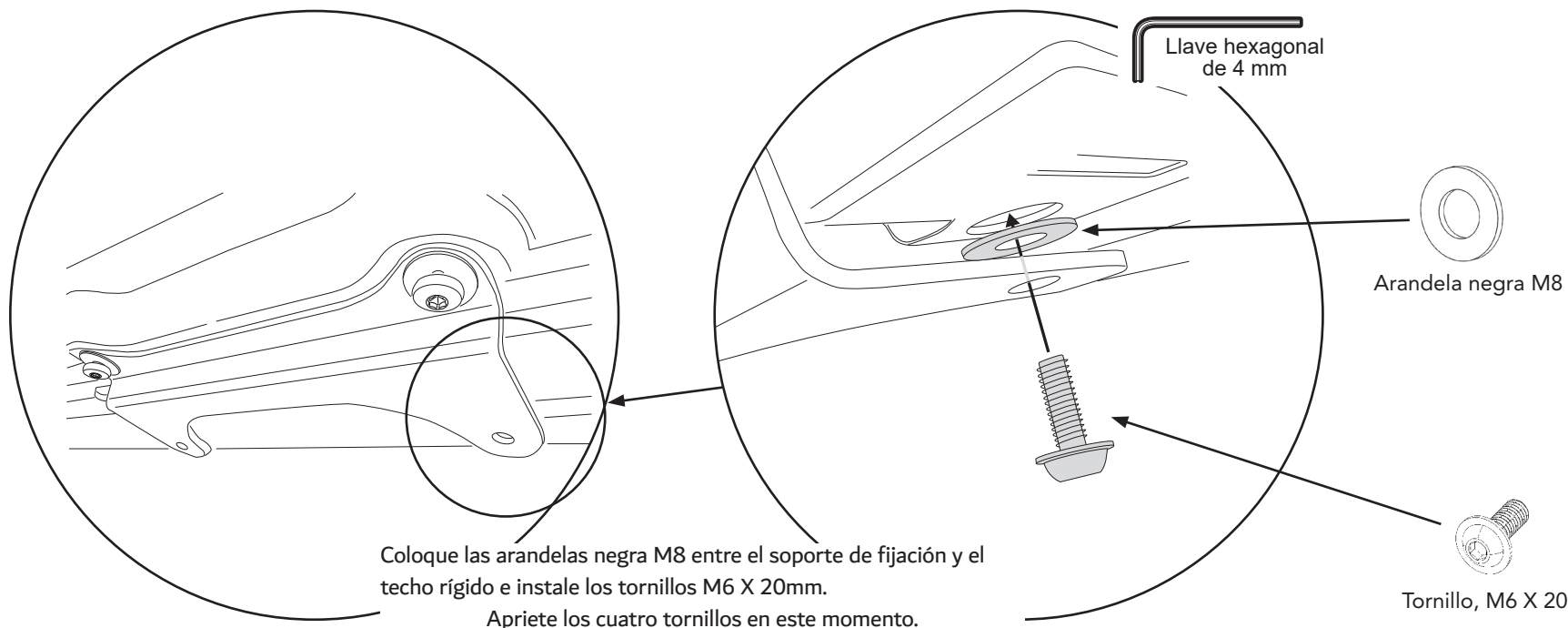
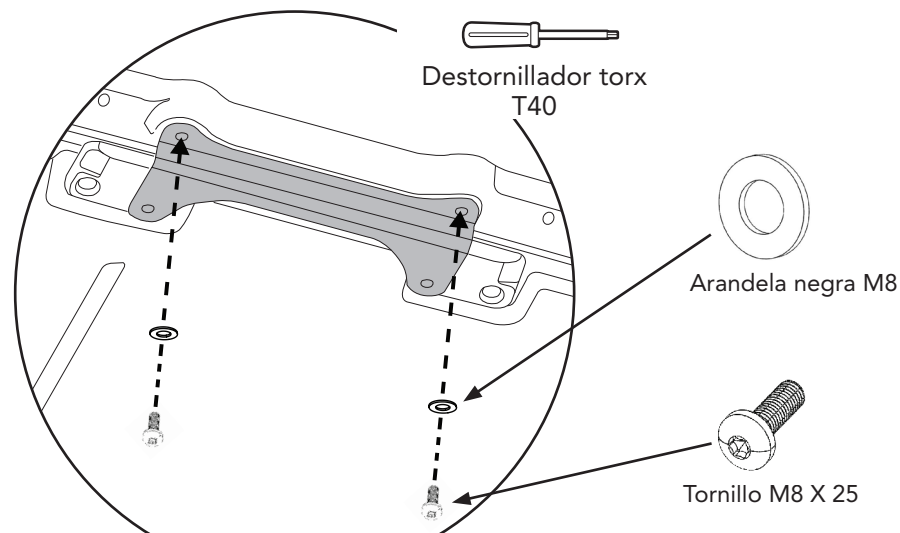
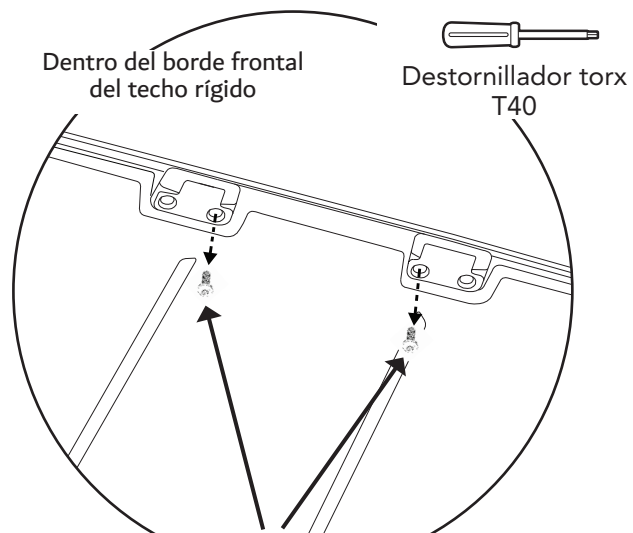

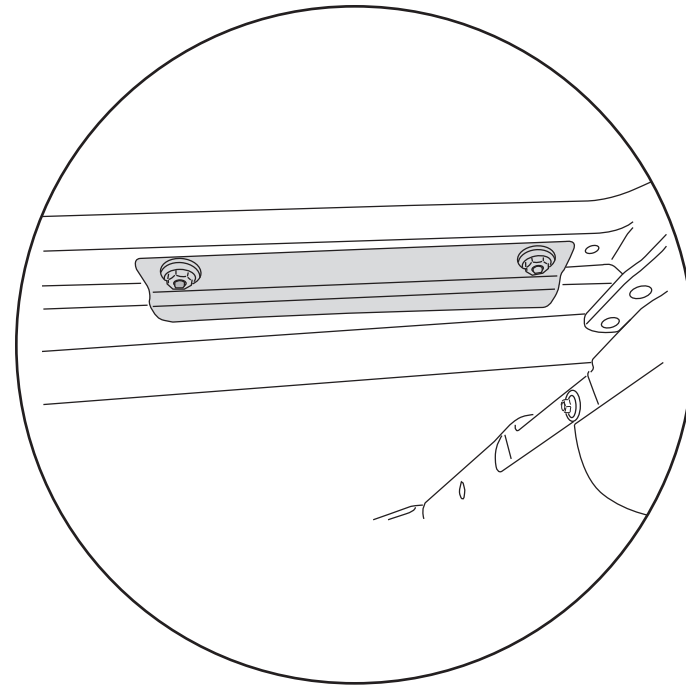
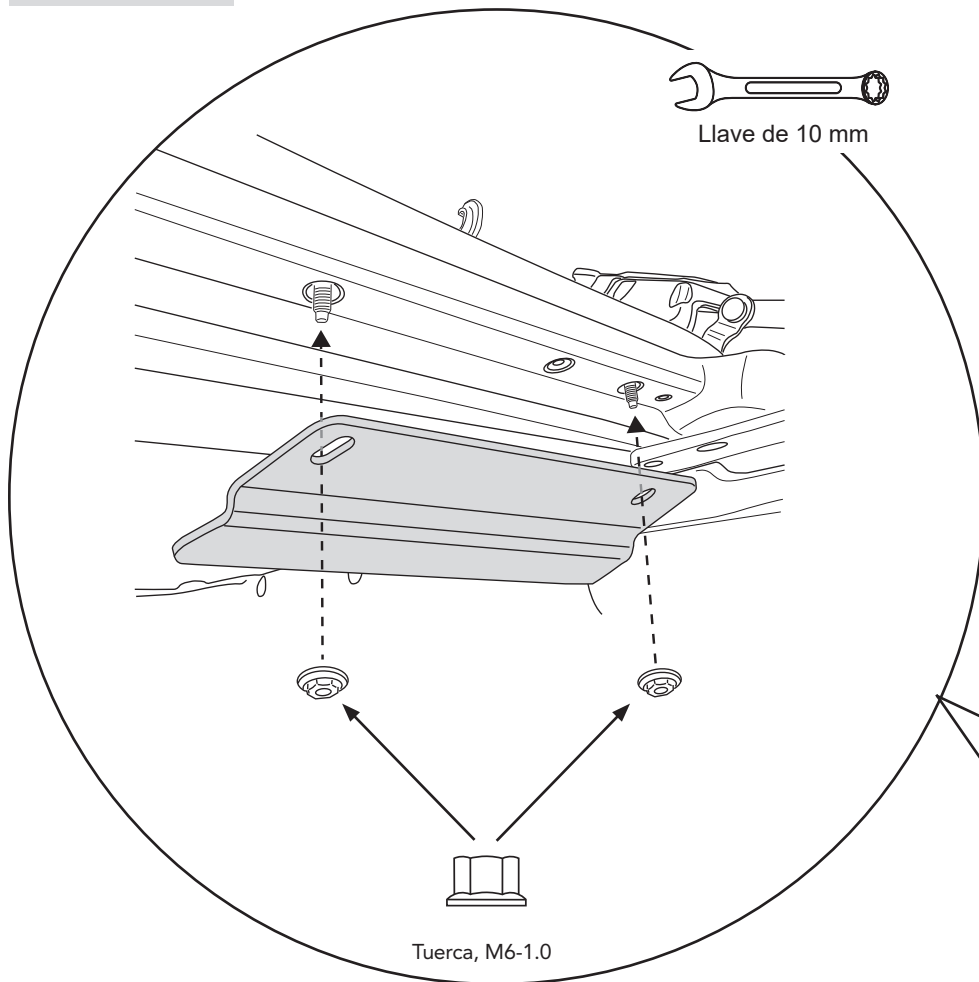

Coloque el soporte de la abrazadera de descenso sobre los dos tornillos que sobresalen con el escalón hacia el borde del techo rígido y, a continuación, coloque y apriete las tuercas M6. Repita en el otro lado del vehículo

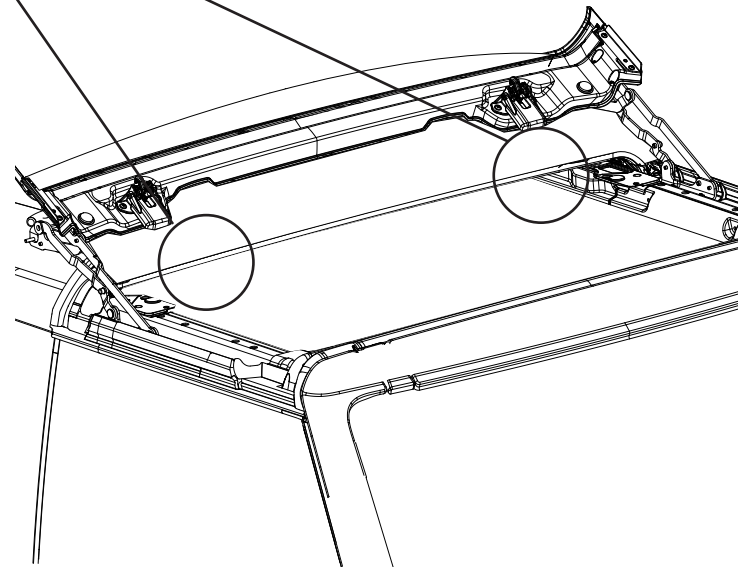



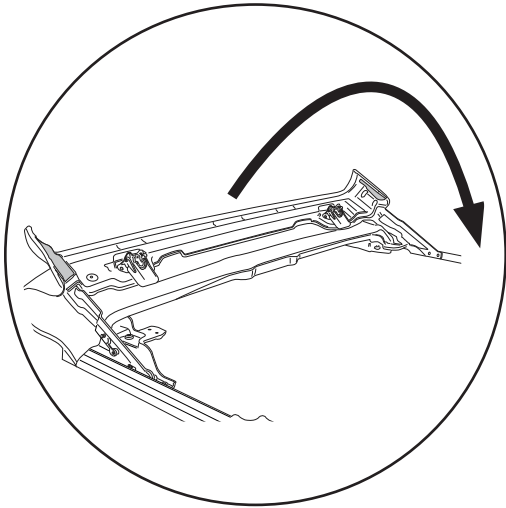

Doblar el Sunrider hacia adelante.

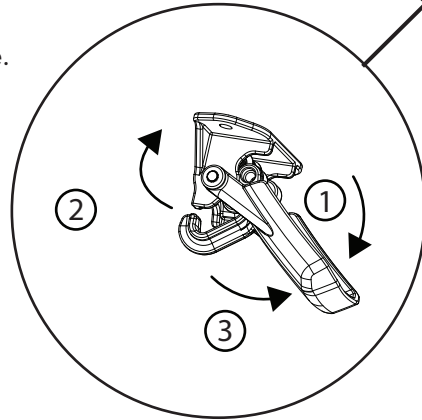
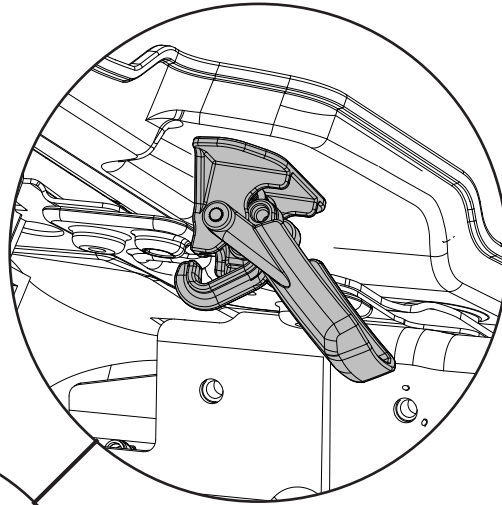

Asegurar ambos cerrojos al cabezal del parabrisas del vehículo.

- ① Girar la manija del cerrojo hacia abajo;
- ② Colocar el gancho;
- ③ Girar la manija del cerrojo de nuevo hacia arriba.

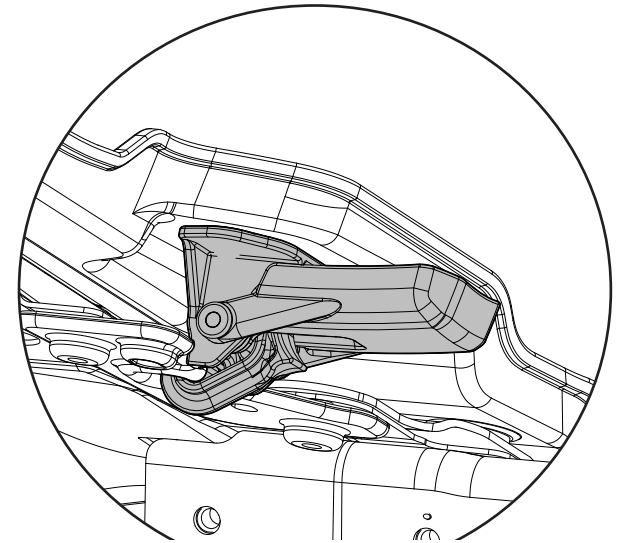

Enganchar en posición cerrada



## Cuidado y mantenimiento de su producto Bestop

Su producto Bestop está fabricado con los mejores materiales disponibles. Para mantenerlo como nuevo y para el máximo desgaste posible, necesitará limpieza y mantenimiento periódicos.

**Tejido:** El tejido debe lavarse a menudo con jabón, agua tibia y un cepillo de cerdas suaves. de jabón. Bestop recomienda el uso de Bestop Cleaner (ref. 11201-00) y Bestop Protectant (ref. 11202-00) para el tejido de vinilo y Bestop Twill Protectant (ref. 11207-00) para el tejido de sarga. Bestop Twill Protectant (parte no. 11207-00) para tejido Twill. Bestop Cleaner y Bestop Protectant están especialmente formulados para proporcionar un sistema total de limpieza y protección. Bestop Cleaner elimina con seguridad las manchas más difíciles, no daña los acabados del vehículo, es biodegradable y respetuoso con el medio ambiente. y respetuoso con el medio ambiente. Bestop Protectant protege contra la decoloración por rayos UV, el agrietamiento y el endurecimiento, y repele el polvo, la grasa, la suciedad y el moho.

**Ventanas:** Mantenga las ventanas limpias para evitar arañazos. NO utilice cepillos en los cristales. Lávelos con un paño o una esponja empapados en agua y un detergente lavavajillas suave. Bestop recomienda el Limpiador de Ventanas de Vinilo Bestop (pieza n° 11203-00), que limpia y protege de forma segura las ventanas de vinilo y ayuda a prevenir los daños causados por los rayos UV. protege los cristales de vinilo y ayuda a prevenir los daños causados por los rayos UV. NUNCA LIMPIE LOS CRISTALES CUANDO ESTÉN SECOS. Tenga cuidado al limpiar nieve o escarcha de los cristales de vinilo, ya que se rayan con facilidad y pueden agrietarse a bajas temperaturas. NO gire las ventanillas trasera cuando haga frío. Las ventanillas se vuelven rígidas y se agrietan. La garantía no cubre las grietas causadas por un uso incorrecto a bajas temperaturas. garantía.

**Agua:** La filtración a través de las costuras puede detenerse aplicando 3-M Scotchgard® en el interior de las costuras.

**Broches:** Mantenga los broches limpios y lubricados con silicona para evitar que se peguen a las tachuelas. Si un broche se queda pegado a un espárrago, utilice un destornillador y haga palanca SUAVEMENTE para evitar daños permanentes en el broche o en el tejido superior.

**Cremalleras:** Mantener las cremalleras limpias y lubricadas con el limpiador de cremalleras de Bestop (pieza n° 11206-00) ayudará a prevenir daños y a mantener las cremalleras en perfectas condiciones de funcionamiento. Si una cremallera se abre por detrás del deslizador, es posible que el deslizador se haya separado. Este problema puede

Este problema puede repararse normalmente utilizando un par de alicates ordinarios para volver a poner los lados en paralelo. Vuelva a colocar el deslizador al final de la cremallera en la posición normal de Apertura. Apriete ligeramente a fi rma y pruebe la cremallera. Si la cremallera continúa abierta apriete más fi rme con los alicates y pruebe de nuevo la cremallera. Repita este procedimiento hasta que la cremallera funcione correctamente.

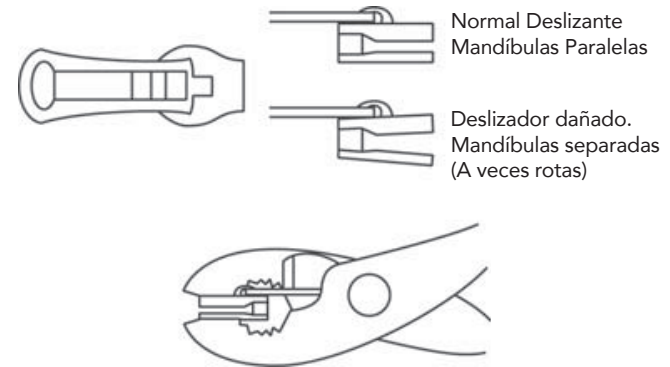

**Para obtener información sobre la garantía de Bestop, visite;**

<https://www.bestop.com/help/warranty-information/>





# Instructions d'installation Sunrider pour berline

Applicable au véhicule :  
Ford Bronco 2 portes 2021-Actuel  
Référence de la pièce 52460

## Conseils d'installation

Avant de commencer à installer votre nouveau Sunrider pour berline, veuillez lire la totalité des instructions et visionner la vidéo d'installation de Bestop. (Voir la section Support à cette page).

Pour faciliter l'installation, la capote doit être installée à une température supérieure à 21 °C (72 °F).

En dessous de cette température, le tissu peut se contracter en compliquant sa pose sur le véhicule.









**⚠️ AVERTISSEMENT** Ne vous fiez en aucune manière aux composants de ce produit pour vous protéger contre des blessures ou la mort en cas d'accident. N'utilisez jamais le véhicule au-delà des spécifications du fabricant.

Lisez et suivez scrupuleusement toutes les instructions d'installation fournies lors de l'installation de ce produit. Ne pas le faire peut entraîner un mauvais ajustement et peut placer les occupants du véhicule dans une situation potentiellement dangereuse.



**⚠️ ATTENTION** Des lunettes de protection doivent être portées à tous moments lors de l'installation de ce produit.

## METTEZ LES CEINTURES DE SÉCURITÉ À TOUS MOMENTS

Outils			Temps d'installation	Assistance
 Sécurité Lunettes	 4 mm Clé hexagonale	 T30, T40 et T50 Tournevis Torx	 30 minutes	Nous sommes là pour vous aider ! Allez à : <a href="https://www.bestop.com">https://www.bestop.com</a> et cliquez sur Need Help (Besoin d'aide) ?
			Niveau de compétence	
			    1 - Facile	
			<a href="https://www.bestop.com/video-library">https://www.bestop.com/video-library</a>	



# Instructions d'installation Sunrider pour berline

Applicable au véhicule :  
Ford Bronco 2 portes 2021-Actuel  
Référence de la pièce 52460

## Liste des pièces

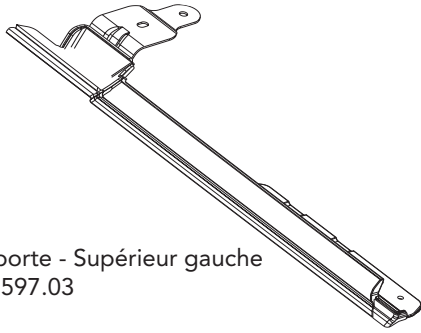

Rail de porte - Supérieur gauche  
Pièce n°597.03  
Qté. 1

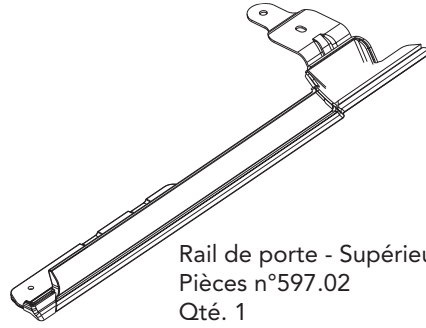

Rail de porte - Supérieur droit  
Pièces n°597.02  
Qté. 1

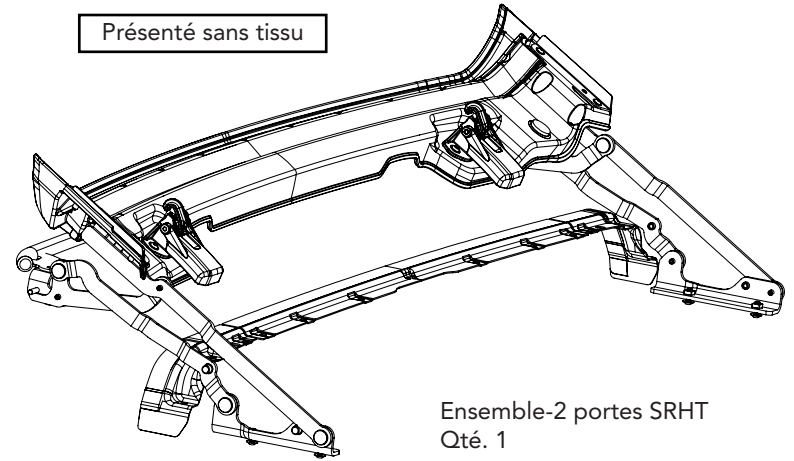

Ensemble-2 portes SRHT  
Qté. 1



Écrou, M6-1.0  
Pièce n°515.82  
Qté. 4

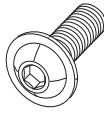

Vis, M6 X 1.00 X 20  
Pièce n°517.48  
Qté. 6

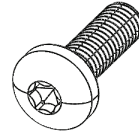

Vis, M8 X 1.25 X 25  
Pièce n°598.93  
Qté. 2

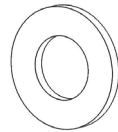

Rondelle M8 noire  
Pièce n°603.26  
Qté. 4

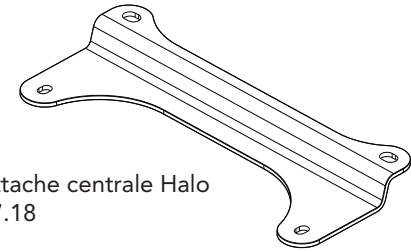

Support, Attache centrale Halo  
Pièce n°597.18  
Qté. 1

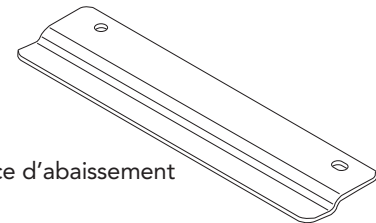

Support de pince d'abaissement  
Pièce n°659.79  
Qty. 2

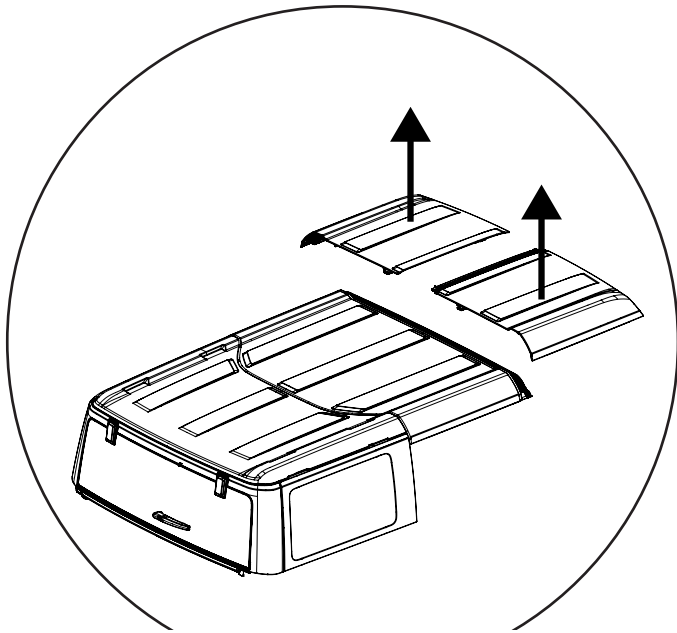

Déposer les panneaux de toit avant. (voir le manuel utilisateur pour les détails)

**Remarque :** La galerie de toit (si elle est équipée) doit être retiré pour le fonctionnement de la capote

Déposer

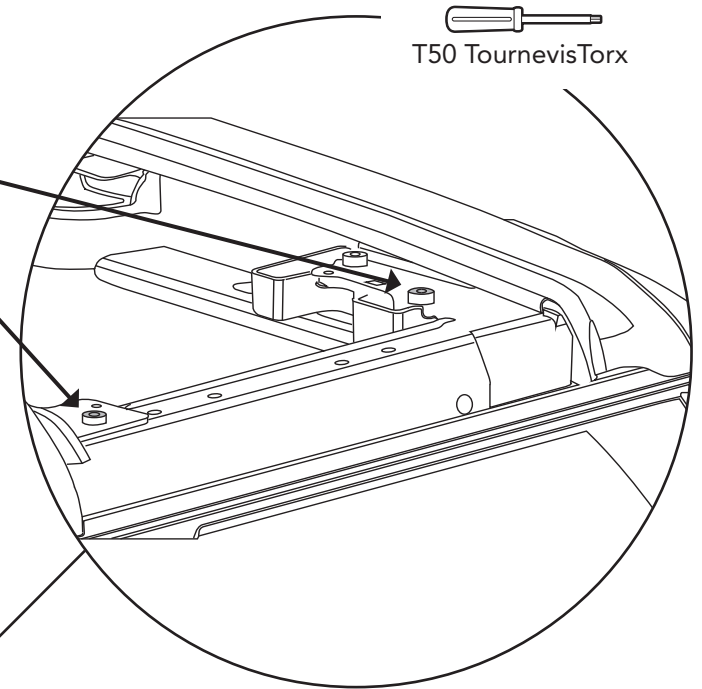

T50 TournevisTorx

Retirer les boulons du véhicule (deux de chaque côté) et conservez-les.

**Remarque :** Ces boulons seront réutilisés ensuite dans l'installation.

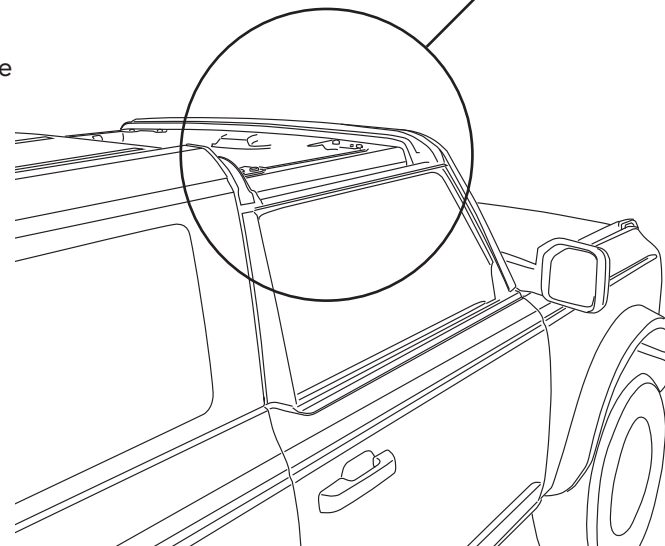

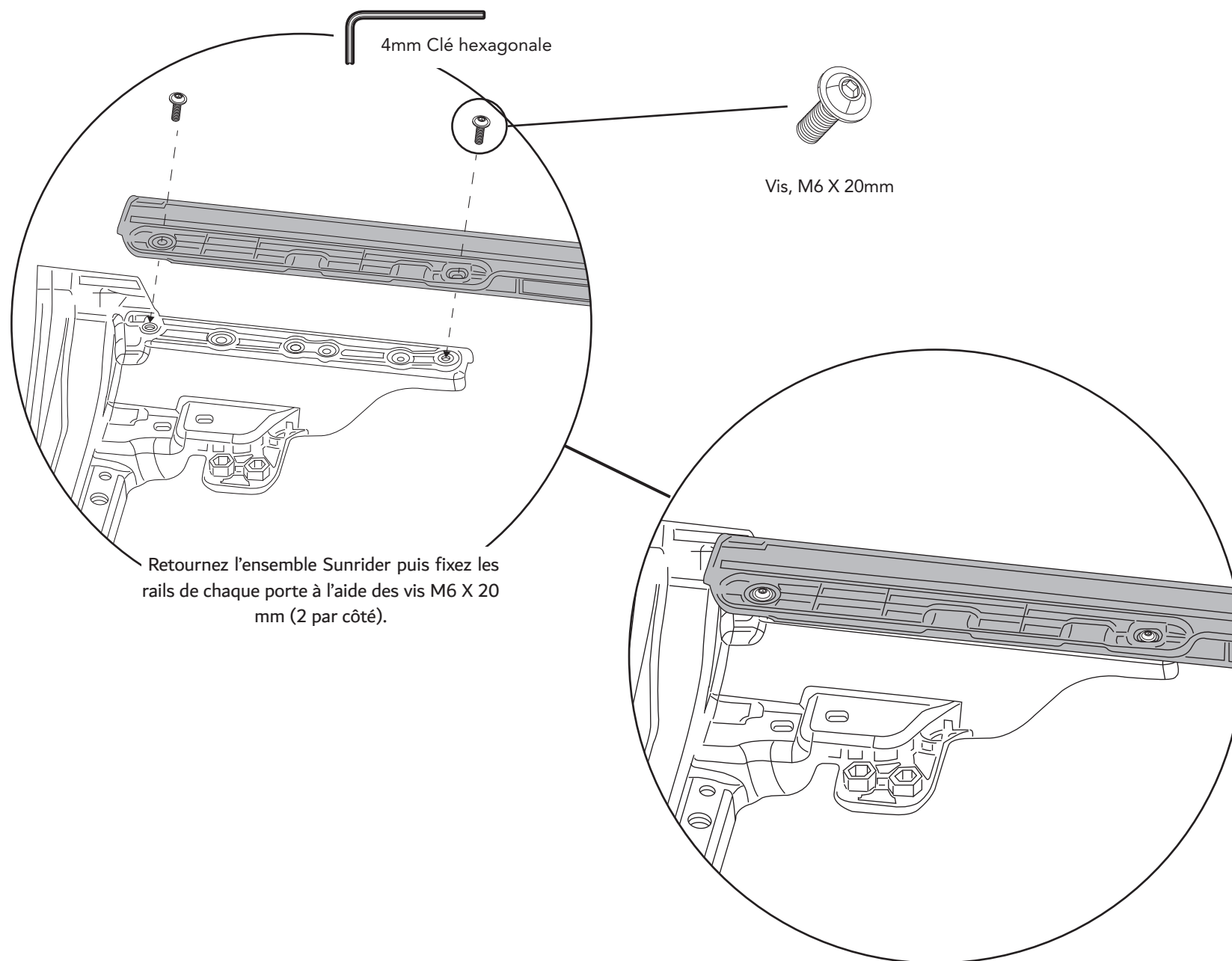

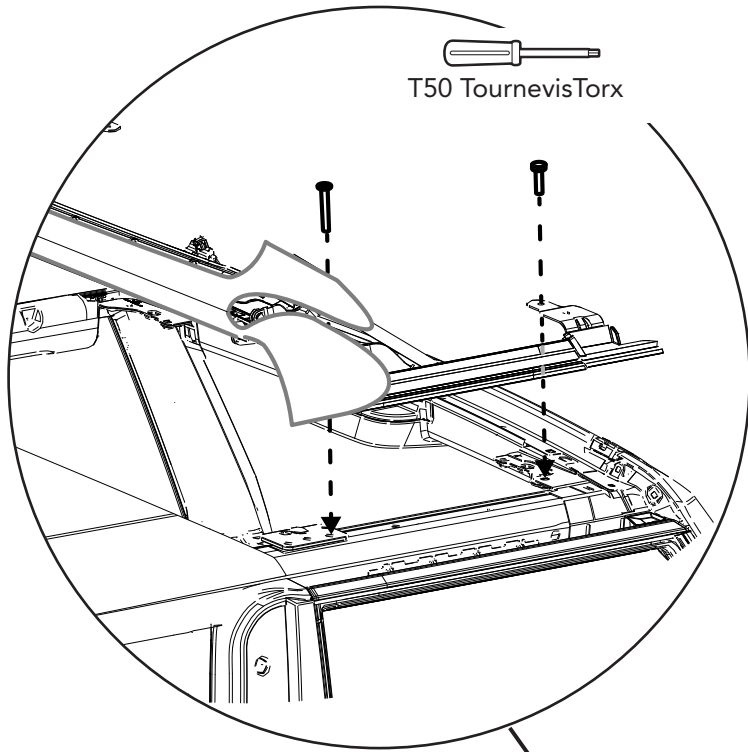

T50 TournevisTorx

Retournez l'assemblage du Sunrider et placez-le sur le véhicule. Utilisez les attaches qui ont été retirées à la section 1 pour fixer le Sunrider au véhicule.

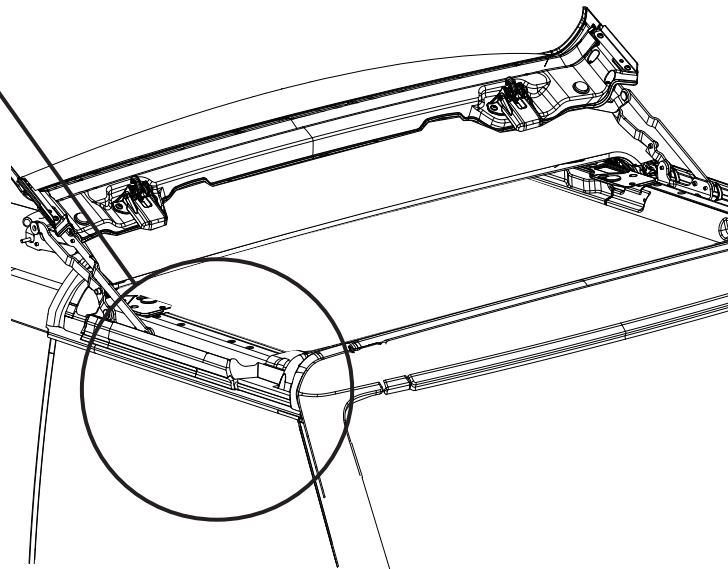

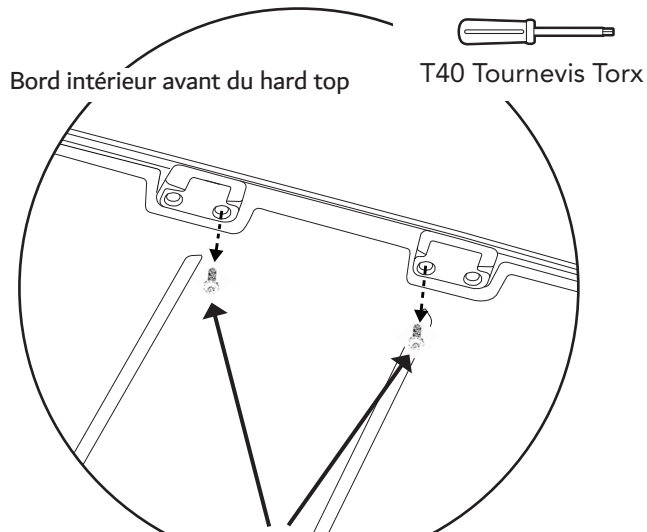

Retirer les vis du récepteur de verrouillage du hardtop et les conserver pour une installation ultérieure du toit rigide.

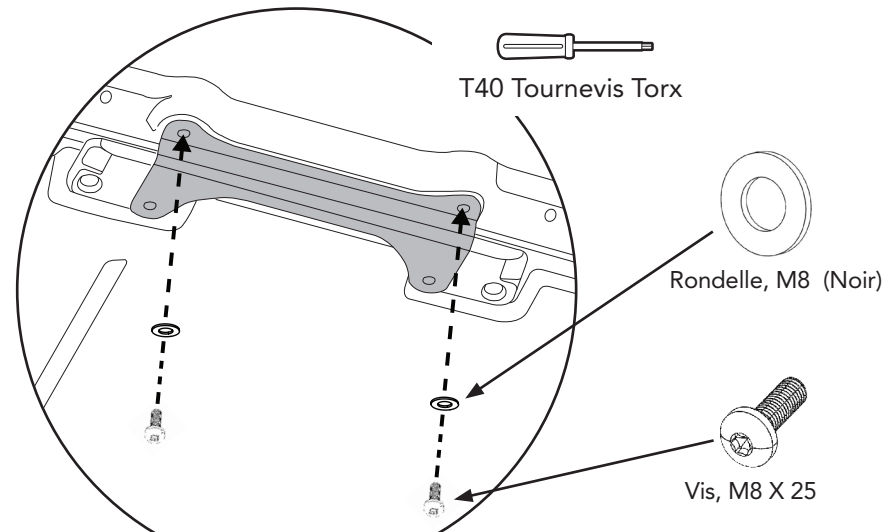

Fixez le support central du halo au Sunrider à l'aide de deux (2) vis M8 X 25 et de deux (2) rondelles M8. Laissez-les libres à ce stade.

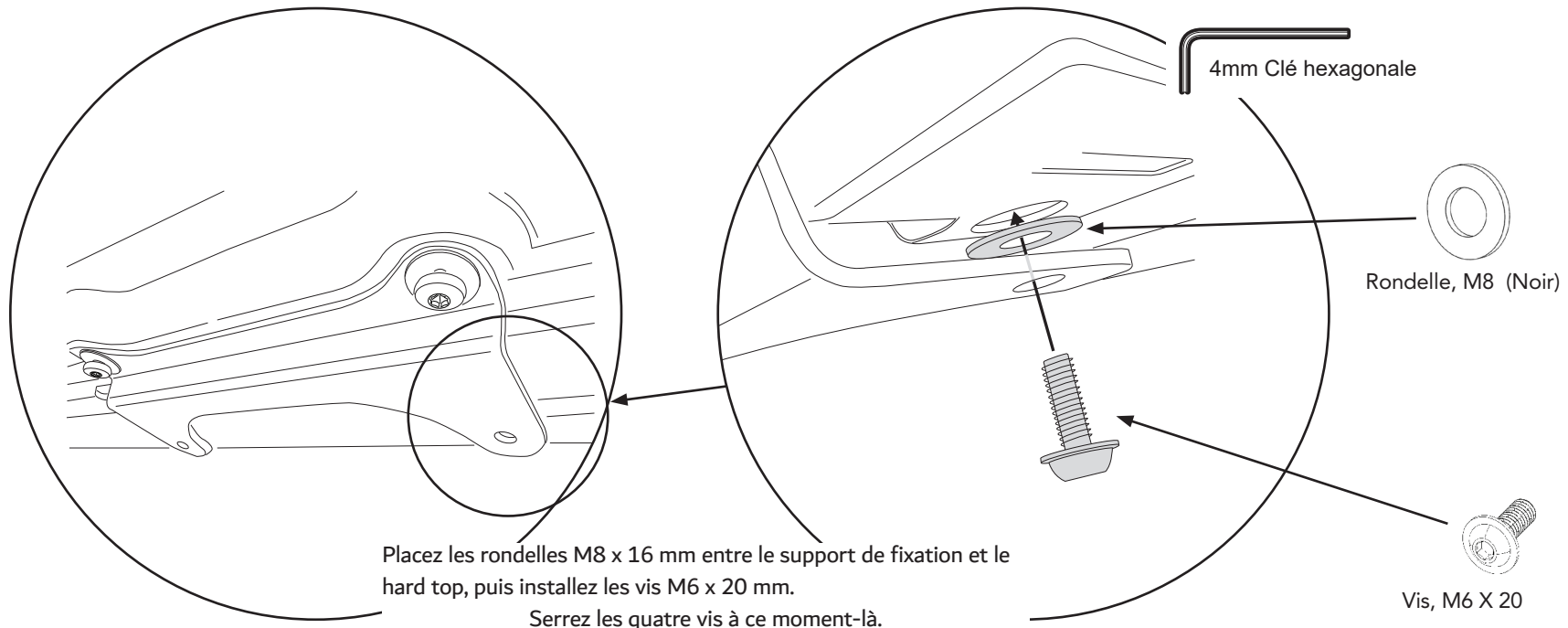



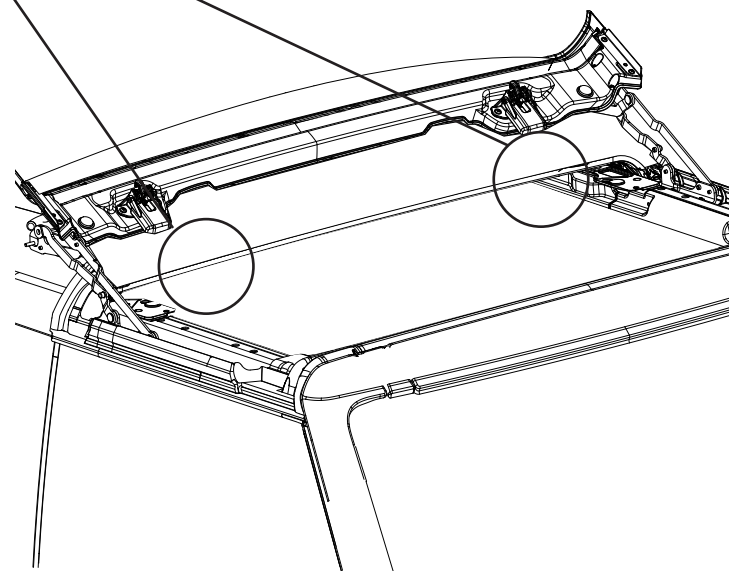
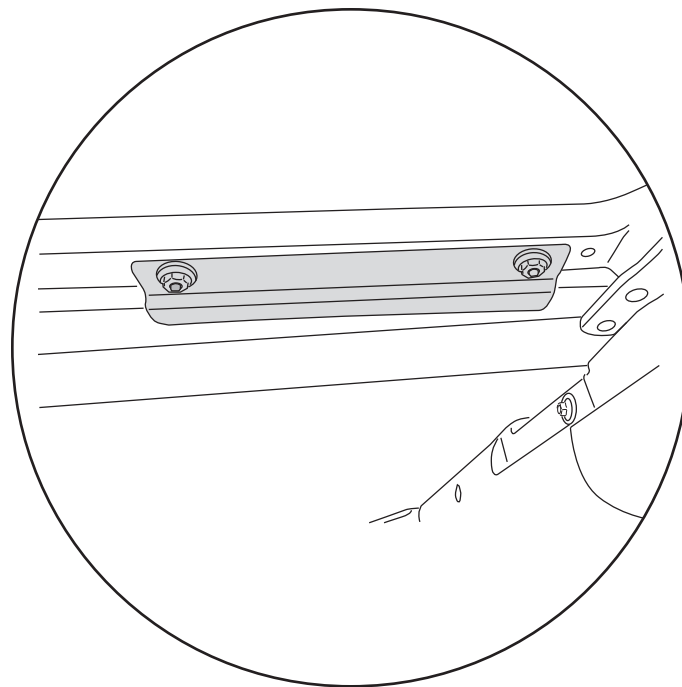
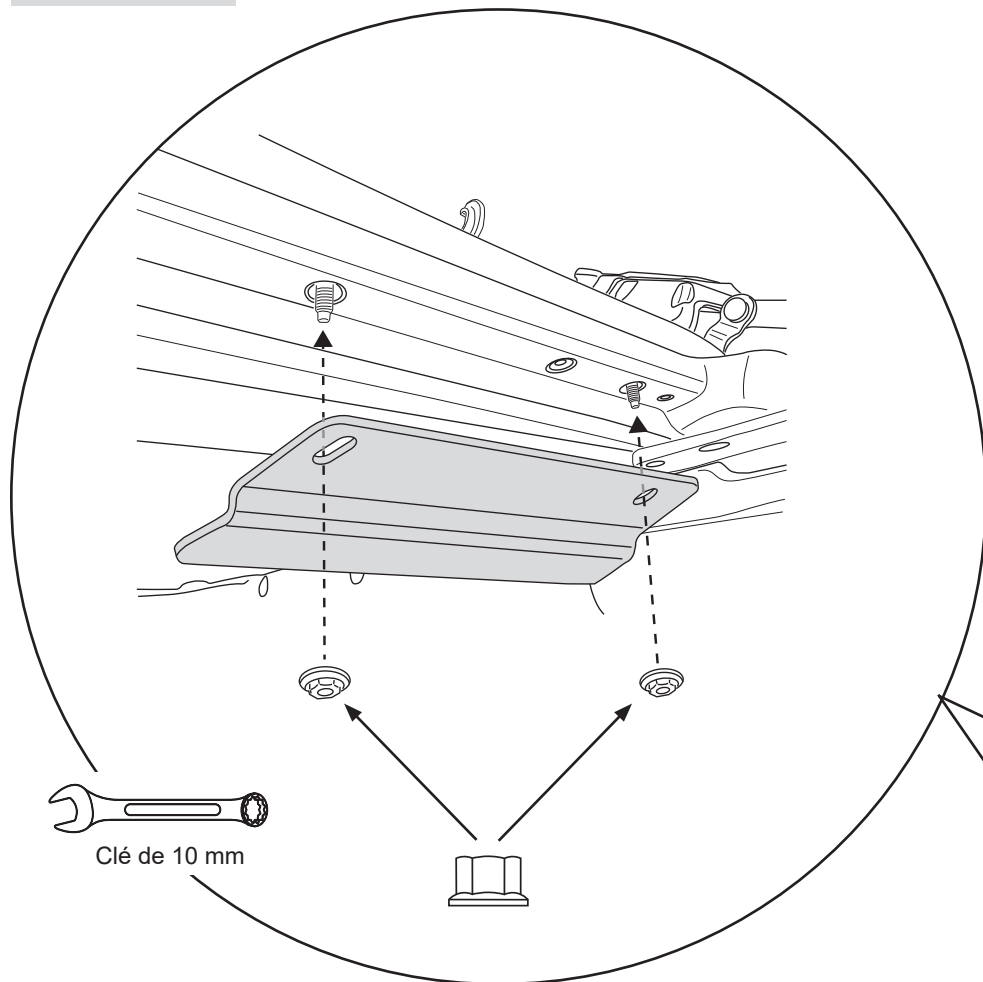

Placer le support de fixation d'abaissement sur les deux vis en saillie, la marche allant vers le bord du hard top, puis placer et serrer les écrous M6. Répéter l'opération de l'autre côté du véhicule.

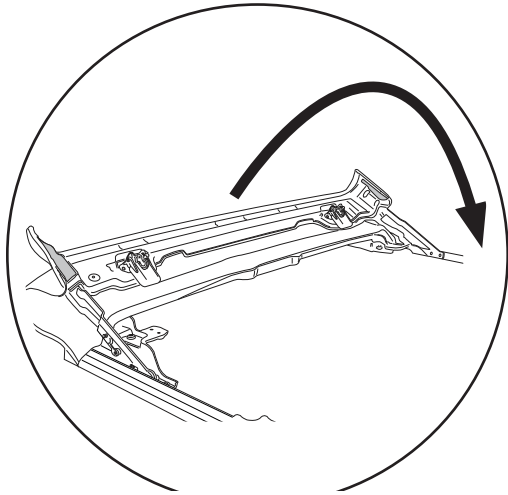

Repliez le Sunrider vers l'avant.

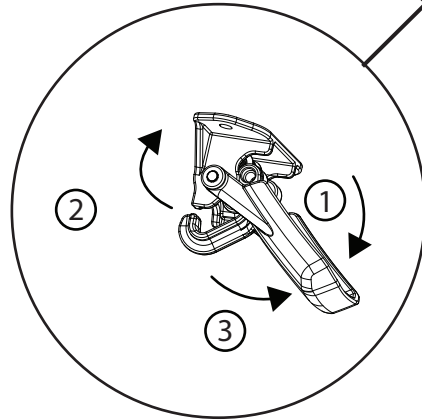
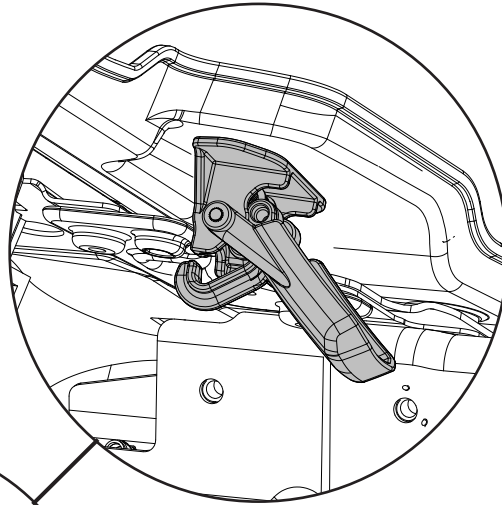

Fixez les loquets à la traverse de pare-brise du véhicule.

- ① Tournez la poignée de verrouillage vers le bas ;
- ② Engagez le crochet ;
- ③ Tournez la poignée de verrouillage de nouveau vers le haut.

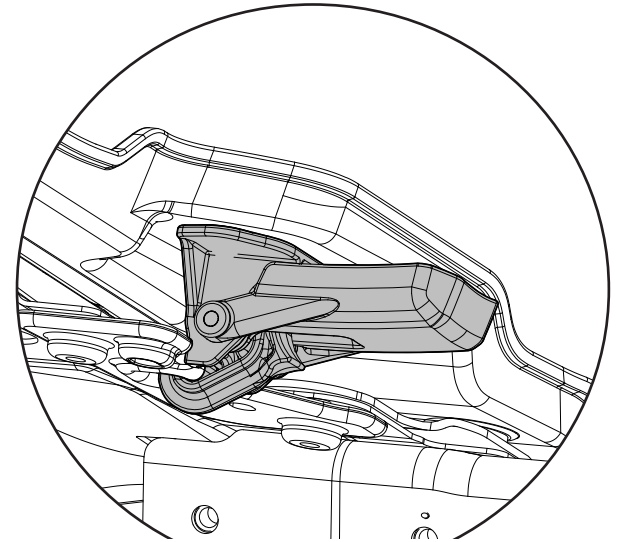

Verrouillez en position fermée



## Entretien et maintenance des produits Bestop

Votre produit Bestop est fabriqué à partir des meilleurs matériaux disponibles. Pour qu'il conserve son aspect neuf et qu'il soit le plus résistant possible, il doit être nettoyé et entretenu périodiquement. d'un nettoyage et d'un entretien périodiques.

**Tissu:** Le tissu doit être lavé souvent avec du savon, de l'eau chaude et une brosse à poils doux. Bestop recommande d'utiliser Bestop Cleaner (référence 11201-00) et Bestop Protectant (référence 11202-00) pour le tissu Vinyl et Bestop Twill Protectant (référence 11207-00) pour le tissu Twill. Bestop Twill Protectant (référence 11207-00) pour le tissu Twill. Le nettoyeur Bestop et le protecteur Bestop sont spécialement formulés pour fournir un système total de nettoyage et de protection. système de nettoyage et de protection complet. Bestop Cleaner élimine en toute sécurité les taches les plus tenaces, n'endommage pas les finitions des véhicules, est biodégradable et respectueux de l'environnement. biodégradable et respectueux de l'environnement. Le Bestop Protectant protège contre la décoloration due aux UV, les craquelures et le durcissement, et repousse la poussière, la graisse, la saleté et la moisissure.

**Fenêtres:** Gardez les fenêtres propres pour éviter les rayures. N'utilisez PAS de brosse sur les vitres ! Lavez-les avec un chiffon ou une éponge imbibés d'eau et un détergent à vaisselle doux. Bestop recommande le nettoyeur pour vitres en vinyle Bestop (référence 11203-00), qui nettoie et protège les vitres en vinyle en toute sécurité et aide à prévenir les dommages causés par les rayons UV. qui nettoie et protège les vitres en vinyle en toute sécurité et aide à prévenir les dommages causés par les UV. N'ESSUYEZ JAMAIS LES VITRES LORSQU'ELLES SONT SÈCHES. Soyez prudent lorsque vous nettoyez la neige ou le givre sur les vitres en vinyle car elles se rayent facilement et peuvent se fissurer à basse température. NE PAS rouler les vitres latérales ou arrière par temps froid. par temps froid. Les vitres deviennent rigides et se fissurent. Les fissures causées par une mauvaise utilisation par temps froid ne sont pas couvertes par la garantie.

**Eau:** Les infiltrations au niveau des coutures peuvent être stoppées en appliquant du Scotchgard® 3-M à l'intérieur des coutures.

**Claquettes:** Nettoyez les boutons-pression et lubrifiez-les avec du silicone pour éviter qu'ils ne collent aux montants. Si un bouton-pression reste collé à un montant, utilisez un tournevis et écartez-le DOUCEMENT pour éviter d'endommager définitivement le bouton-pression ou le tissu supérieur.

**Fermetures à glissière:** Le nettoyage et la lubrification des fermetures éclair à l'aide du nettoyeur pour fermetures éclair Bestop (référence 11206-00) permettent d'éviter les dommages et de maintenir les fermetures éclair en bon état de fonctionnement. Si une fermeture éclair s'ouvre derrière le curseur, il se peut que le curseur ait été écarté. Ce problème peut généralement être réparé en utilisant une pince ordinaire pour remettre les côtés en parallèle. Replacez le curseur à l'extrémité de la fermeture à glissière en position normale d'ouverture. Pressez légèrement au début et testez la fermeture à glissière. Si la fermeture reste ouverte, serrez plus fort avec la pince et essayez à nouveau la fermeture à glissière. Répétez cette procédure jusqu'à ce que la fermeture éclair fonctionne correctement.

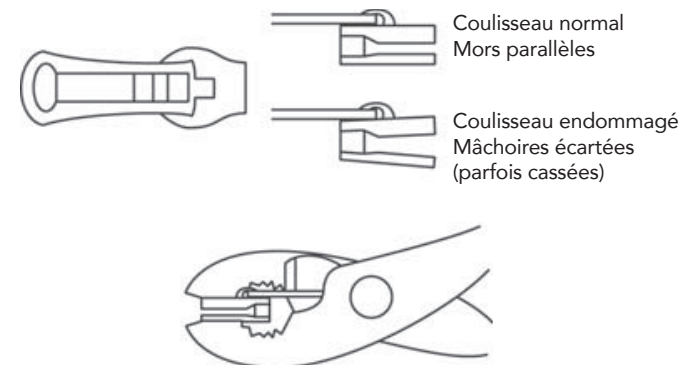

**Pour obtenir des informations sur la garantie Bestop, veuillez consulter;**

<https://www.bestop.com/help/warranty-information/>

