



Installation Instructions Supertop Ultra

Vehicle Application:
Jeep® JL Wrangler Unlimited 2019 - Current
Part Number 54725

Installation Tips

Before you begin installing your new Supertop Ultra, please read all the instructions thoroughly.

For a smooth fit:

For easier installation, the top should be installed at a temperature above 72°F. Below this temperature, the fabric may contract an inch or more, making it difficult to fit the vehicle.

It is normal for the fabric to contract and wrinkle when stored in the shipping carton. Within a few days after installation, the fabric will relax and the wrinkles will disappear.

WARNING Do not rely in any way on the components of this product to protect against injury or death in the event of an accident. Never operate the vehicle in excess of manufacturer's specifications.

Read and follow, precisely, all installation instructions provided when installing this product. Failure to do so may result in a poor fit and could place occupants of the vehicle in a potentially dangerous situation.

CAUTION Safety glasses should be worn at all times when installing this product. **WEAR SEAT BELTS AT ALL TIMES**



Tools			
			- OR -
Safety Glasses	Ratchet	10mm Socket	10mm Wrench
Step Ladder	Phillips Screwdriver	4mm Allen Wrench	T20-T25-T30-T40-T50 Torx Drivers
	Flat Blade Screwdriver	Super Glue	Torque Wrench

Installation Time
4 hours

Skill Level
<div style="display: flex; justify-content: space-around; align-items: center;"> <div style="border: 1px solid black; border-radius: 50%; width: 30px; height: 30px; display: flex; align-items: center; justify-content: center;">1</div> <div style="border: 1px solid black; border-radius: 50%; width: 30px; height: 30px; display: flex; align-items: center; justify-content: center;">2</div> <div style="border: 2px solid black; border-radius: 50%; width: 30px; height: 30px; display: flex; align-items: center; justify-content: center;">3</div> <div style="border: 1px solid black; border-radius: 50%; width: 30px; height: 30px; display: flex; align-items: center; justify-content: center;">4</div> </div> <p>3 - Moderately Difficult</p>

Support
<p>We're here to help! Go to: https://www.bestop.com and click on Need Help?</p>
<p>https://www.bestop.com/video-library</p>



Installation Instructions Supertop Ultra

Vehicle Application:
Jeep® JL Wrangler Unlimited 2019 - Current
Part Number 54725

Sugerencias de Instalación

Antes de empezar a instalar esta unidad, lea atentamente todas las instrucciones.

Para un buen ajuste:

Para facilitar la instalación, el producto debe instalarse a temperaturas superiores a 72 °F (22 °C).

Por debajo de esta temperatura, la tela puede encogerse una pulgada o más, lo que dificultaría su ajuste al vehículo.

Es normal que la tela se contraiga o arrugue cuando está guardada en la caja de empaque. A los pocos días después de la instalación, la tela se relajará y las arrugas desaparecerán.



ADVERTENCIA

Este producto se diseñó principalmente para mejorar la apariencia del vehículo y proteger a los ocupantes de las condiciones climáticas comunes. De ninguna manera piense que los componentes de este producto pueden servir como medio de contención para los ocupantes del vehículo o que pueden protegerlos contra lesiones o la muerte en caso de accidente. Este producto no protegerá a los ocupantes contra caídas de objetos. Nunca conduzca este vehículo fuera de las especificaciones del fabricante.

USE LOS CINTURONES DE SEGURIDAD EN TODO MOMENTO

Lea y siga con precisión todas las instrucciones de instalación que se proporcionan para instalar este producto. Si no lo hace, podría producirse un mal ajuste que colocaría a los ocupantes del vehículo en una situación potencialmente peligrosa.



PRECAUCIÓN

Debe usar gafas protectoras en todo momento durante la instalación de este producto.

Conseils pour l'installation

Lire toutes les instructions au complet avant de commencer l'installation de cet assemblage.

Pour un ajustement sans problème :

Afin de faciliter l'installation, ce produit doit être installé à des températures au-dessus de 72 °F (22 °C).

Sous cette température, le tissu peut rétrécir d'un pouce (2,5 cm) ou plus, ce qui rendra l'ajustement sur le véhicule difficile.

Il est normal que le tissu rétrécisse et plisse pendant qu'il est dans la boîte d'expédition. En quelques jours après l'installation, le tissu se détendra et les plis disparaîtront.



AVERTISSEMENT

Ce produit est conçu principalement pour améliorer l'apparence du véhicule et pour protéger les occupants des conditions météorologiques usuelles. Ne jamais se fier aux composants de ce produit pour se protéger de blessures ou de la mort en cas d'accident. Ce produit ne protégera pas les occupants des chutes d'objets. Ne jamais utiliser le véhicule au-delà des caractéristiques techniques indiquées par le fabricant.

PORTER UNE CEINTURE DE SÉCURITÉ EN TOUT TEMPS

Lire et suivre, très fidèlement, toutes les instructions d'installation fournies lors de l'installation de ce produit. Ne pas suivre cette consigne peut causer une installation inadéquate et mettre les occupants du véhicule dans une situation potentiellement dangereuse.



MISE EN GARDE

Des lunettes de sécurité doivent être portées en tout temps lors de l'installation de ce produit.



Installation Instructions Supertop Ultra

Vehicle Application:
Jeep® JL Wrangler Unlimited 2019 - Current
Part Number 54725

Parts List



Upper Rear Door Rail
Part #585.94 - Right
Qty. 1



Upper Rear Door Rail
Part #585.95 - Left
Qty. 1

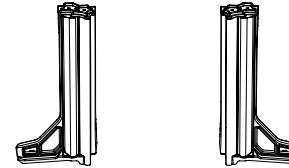

Lower Rear Door Rail
Part #574.46 - Right
Part #574.47 - Left
Qty. 1

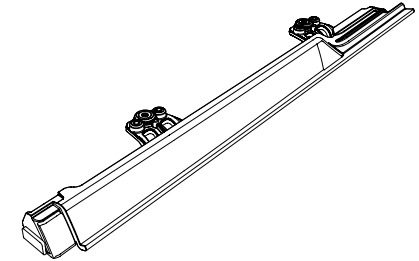

Front Door Rail
Part #574.32 - Right (shown)
Part #574.33 - Left
Qty. 1 of each

Parts Kit #574.62P

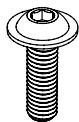

M6x20mm
Flanged Button Head
Cap Screw
#517.48
Qty. 4

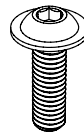

M8x1.25x20mm
Flanged Button Head
Cap Screw
#573.09
Qty. 2



M8 Flat Washer
#515.84
Qty. 2

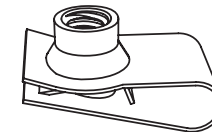

M6 U-Clip
#537.49
Qty. 4

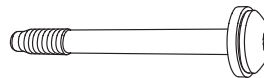

M8x1.25x80
Screw
#532.23
Qty. 8



Installation Instructions Supertop Ultra

Vehicle Application:
Jeep® JL Wrangler Unlimited 2019 - Current
Part Number 54725

Parts List

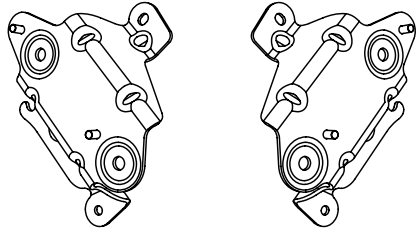

Sport Bar Mounting Brackets
Part #590.02 - Right
Part #590.03 - Left
Qty. 1 of each

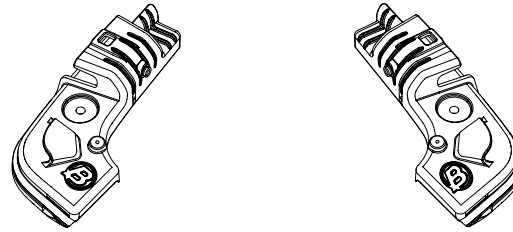

Tailgate Bar Retainers
Part #575.39 - Left
Part #575.38 - Right
Qty. 1 of each

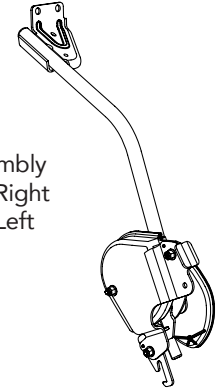

Lift Assist Assembly
Part #589.98 - Right
Part #589.99 - Left
Qty. 1 of each

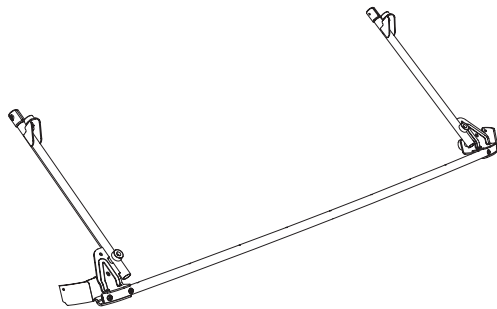

#6 Bow Assembly
Part #589.25
Qty. 1

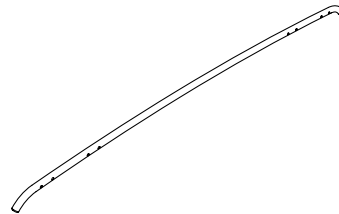

#5 Bow
Part #593.55
Qty. 1

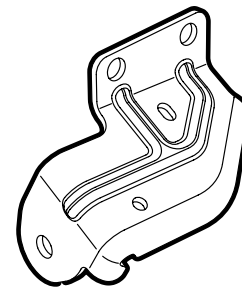

#5 Bow Pivot Bracket
Part #589.19 - Left (shown)
Part #589.18 - Right
Qty. 1 of each

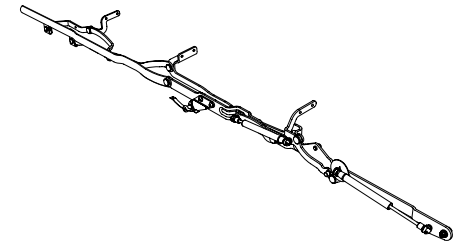

Side Bow Assemblies
Part #585.72 - Right
Part #585.73 - Left (shown)
Qty. 1 of each



Installation Instructions Supertop Ultra

Vehicle Application:
Jeep® JL Wrangler Unlimited 2019 - Current
Part Number 54725

Parts List

Parts Kit #585.93P

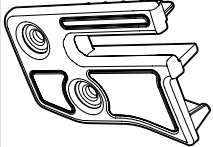

Rear Door Rail Covers
Part #589.48 - Right
Part #589.49 - Left (shown)
Qty. 1 of each

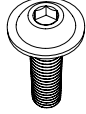

M6 x 1.0 x 10mm
Flanged Allen Screw
Part #572.83
Qty. 4

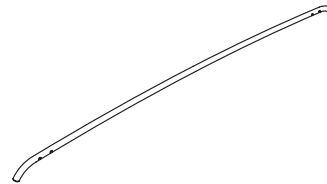

#4 Bow
Part #583.03
Qty. 1

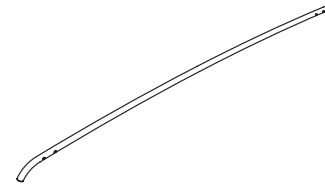

#3 Bow
Part #583.01
Qty. 1

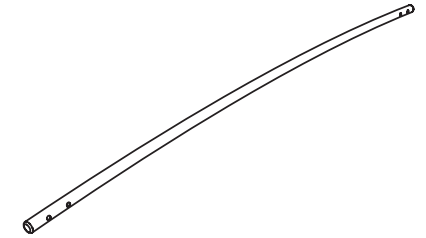

#2 Bow
Part #582.99
Qty. 1

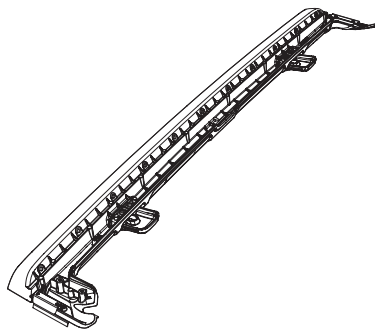

#1 Bow-Fabric Deck
Part #592.88
Qty. 1

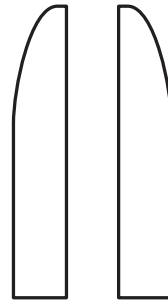

Foam Seals
Part #573.20 (right)
Part #573.21 (left)
Qty. 1 of each

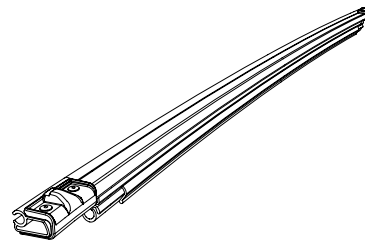

Tailgate Bar
Part #575.33
Qty. 1

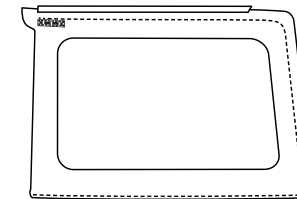

Quarter Windows
Left and Right
Qty. 1 of each

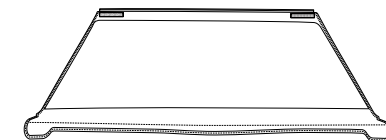

Rear Window
Qty. 1



Installation Instructions Supertop Ultra

Vehicle Application:
Jeep® JL Wrangler Unlimited 2019 - Current
Part Number 54725

Parts Kit #587.70P

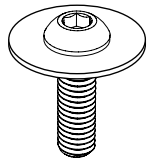

M8x1.25x28
Button Head
Socket Cap
Screw/Washer
Part #534.24
Qty. 4

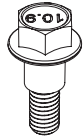

M8 Shoulder Screw
Part #586.72
Qty. 2

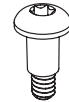

T30 Torx
Shoulder Screw
Part #308.65
Qty. 2

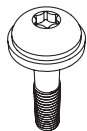

M8x1.25x35
Button Head
Socket Cap
Screw/Washer
Part #532.17
Qty. 2



Thick Plastic Bushing
Part #570.42
Qty. 2



Sheet Metal
Screw
Part #393.79
Qty. 17

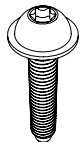

M6x1.0x30
Flanged Torx Screw
Part #533.19
Qty. 8



Thin Plastic Bushing
Part #532.78
Qty. 2

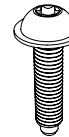

M6x1.0x20
Flanged Torx Screw
Part #533.84
Qty. 4



M6 Flanged Nut
Part #591.47
Qty. 4

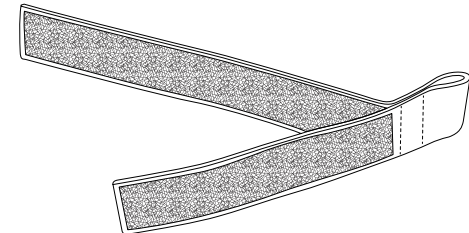

Lift Assist Tie-Down Strap
Part #590.76
Qty. 2

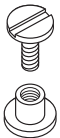

Screw-Binding Barrel
Part #599.01
Qty. 2



Grommet
Part #543.75
Qty. 2



M6x1.0x25
Flanged Torx Screw
Part #535.23
Qty. 12

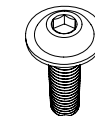

M6 x 1.0 x 10mm
Flanged Allen Screw
Part #572.83
Qty. 4

Parts

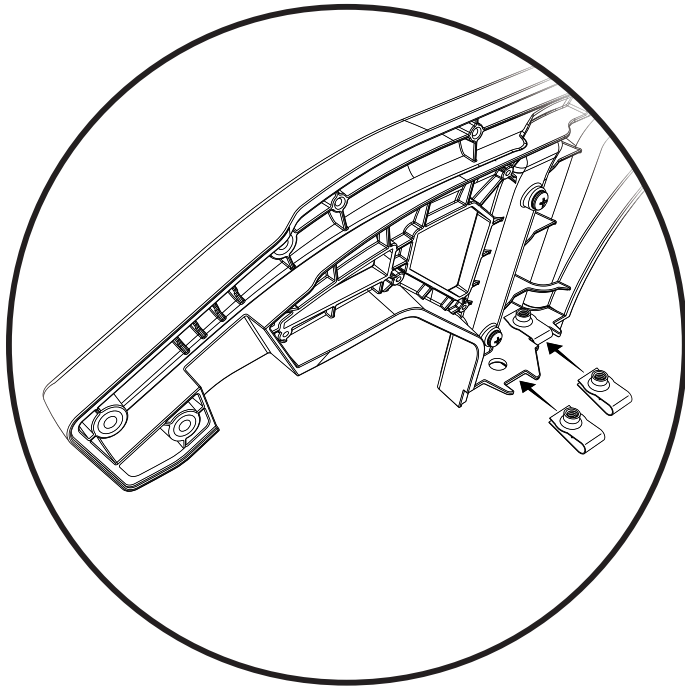

Attach the two (2) U-Clips to the Upper Rear Door Rails (right) and (left) in the positions indicated. Make sure to have the threaded barrel of each U-Clip facing up.



Upper Rear Door Rail
Part #585.94 - Right
Part #585.95 - Left
Qty. 1 of each



Lower Rear Door Rail
Part #574.46 - Right
Part #574.47 - Left
Qty. 1 of each

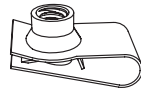

M6 U-Clip
#537.49
Qty. 4

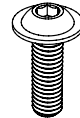

M6x20mm
Flanged Button Head
Cap Screw
#517.48
Qty. 4

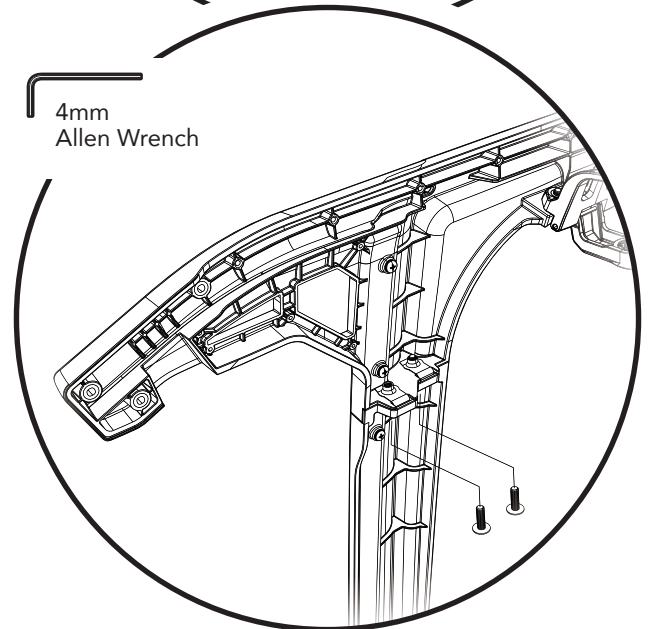
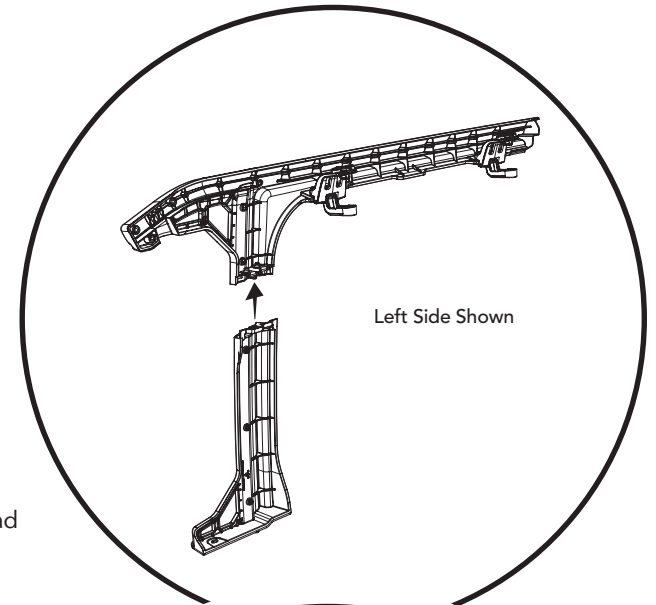

Attach the Upper Rear Door Rail (right) to the Lower Rear Door Rail (right).

Attach the Upper Rear Door Rail (left) to the Lower Rear Door Rail (left).

Use two (2) Button Head Cap Screws (can be found in Small Parts Kit #574.62P) per assembly.

Screws thread up from the bottom into the U-Clips.

Parts



M8 x 1.25 x 20
Screw
#573.09
Qty. 2



M8 x 1.25 x 80
Screw
#532.23
Qty. 8



M8 Flat Washer
#515.84
Qty. 2



Front Door Rail
Part #574.33 - Left
Part #574.32 - Right
Qty. 1

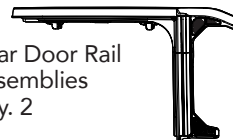

Rear Door Rail
Assemblies
Qty. 2

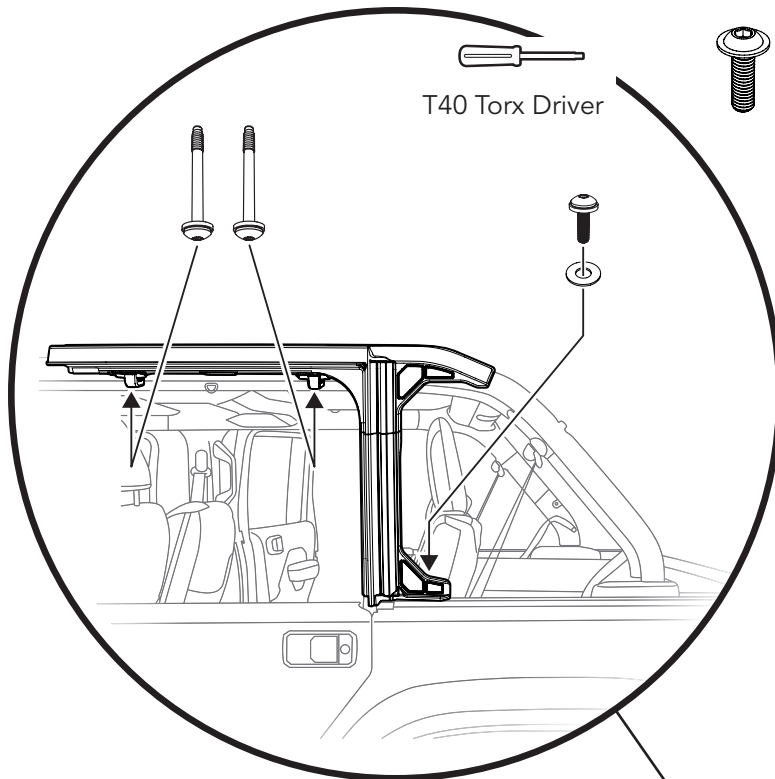

Attach the Rear Door Rail Assemblies to the Jeep. Place each Rear Door Rail Assembly onto the Jeep just behind the rear door.

Align the hole in the lower portion of the Assembly with the threaded hole in the Jeep belt rail, the alignment pin on the bottom of the Assembly with the receiving hole in the top of the belt rail, and the two integral brackets along the top of the Assembly with the through-holes in the Jeep Sport Bar.

Insert two (2) M8x1.25x80 Screws up from the bottom of the integral brackets and tighten to 55 in/lb (4.5 ft/lb).

Use one (1) M8x1.25x20 screw and one (1) M8 Flat Washer on each Assembly to secure the Assembly to the Jeep belt rail.

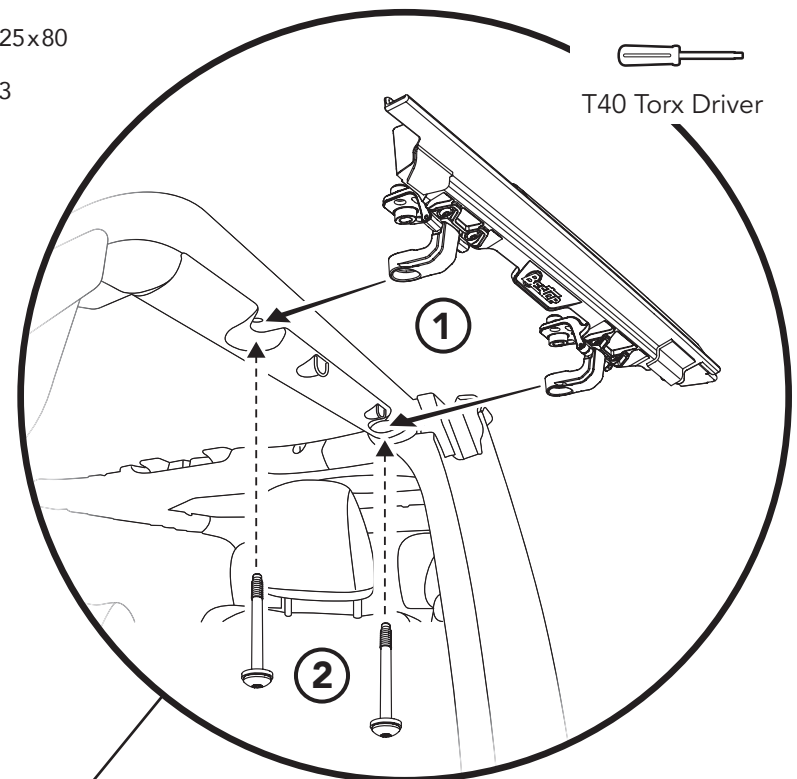

Attach the Front Door Rails to the Jeep.

① Place each Front Door Rail (left) and (right) on the Jeep, aligning the rail brackets with the through-holes in the Jeep sport bar.

② Secure each Front Door Rail to the sport bar using two (2) M8x1.25x80 Socket Cap Screws.

Insert the screws from the bottom and tighten to 55 in/lb (4.5 ft/lb).

Note: To prevent over torquing, Use a Screwdriver type Torx driver if a torque wrench is not available.

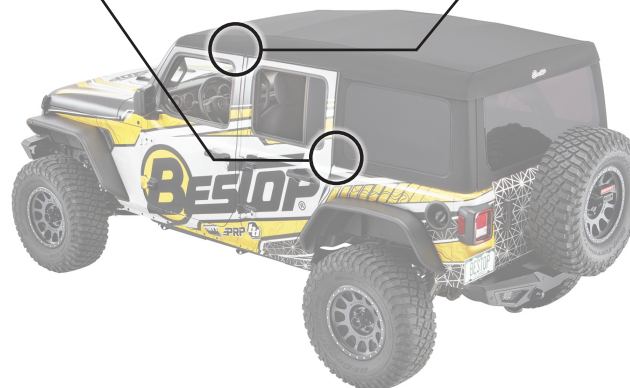

Parts

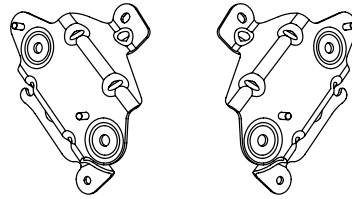

Sport Bar Mounting
Brackets
Part #590.02 - Right
Part #590.03 - Left
Qty. 1 of each

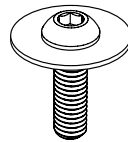

M8x1.25x28
Button Head
Socket Cap
Screw/Washer
Part #534.24
Qty. 4

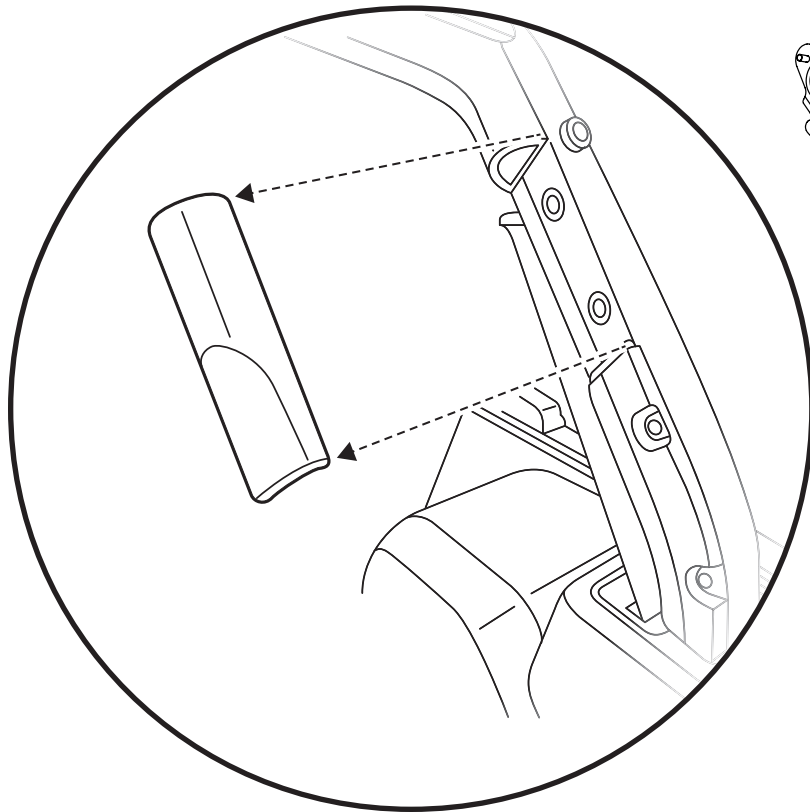

Snap off the trim panel on the rear downtube of the Sport Bar on each side.

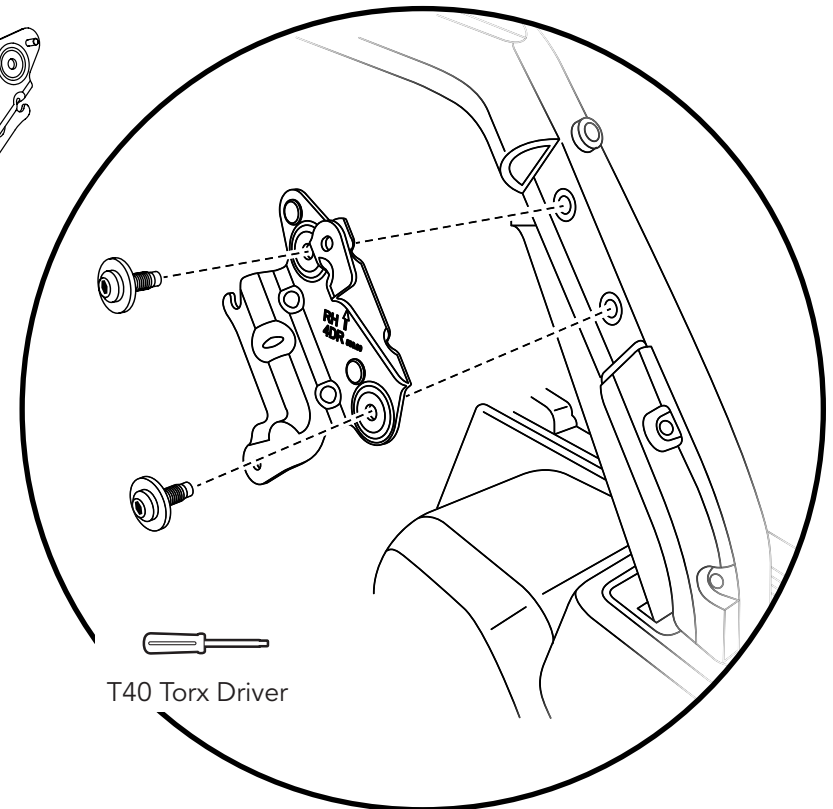

Attach the Sport Bar Mounting Brackets (right) and (left) to the Sport Bar downtubes as shown, using two (2) M8x1.25x28 Button Head Socket Cap Screw/Washers per bracket.

Attach brackets to both left and right side sport bar rear downtubes.

NOTE: The orientation of the brackets as shown, The studs will point to the outside of the vehicle.

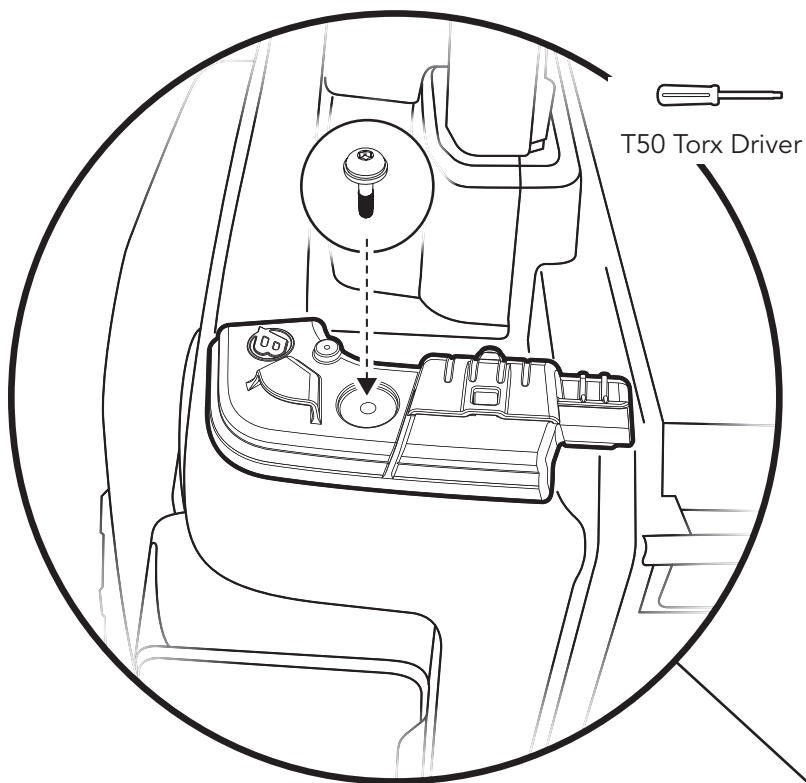

T50 Torx Driver

Parts



Tailgate Bar Retainer
Part #575.38 - Right
Qty. 1

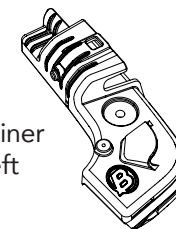

Tailgate Bar Retainer
Part #573.39 - Left
Qty. 1



M8x1.25x35
Button Head
Socket Cap Screw
#532.17
Qty. 2

Attach the Tailgate Bar Retainers (right) and (left) to the Jeep Belt Rail, using one (1) M8x1.25x38 Button Head Socket Cap Screw per retainer.

Insert the screws through the retainers, and into threaded holes in the top of the Jeep belt rail, and tighten.

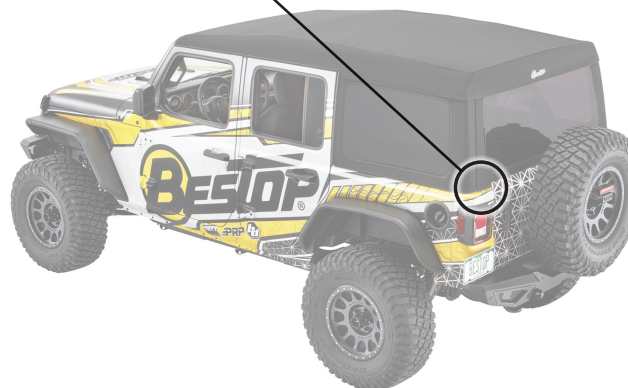

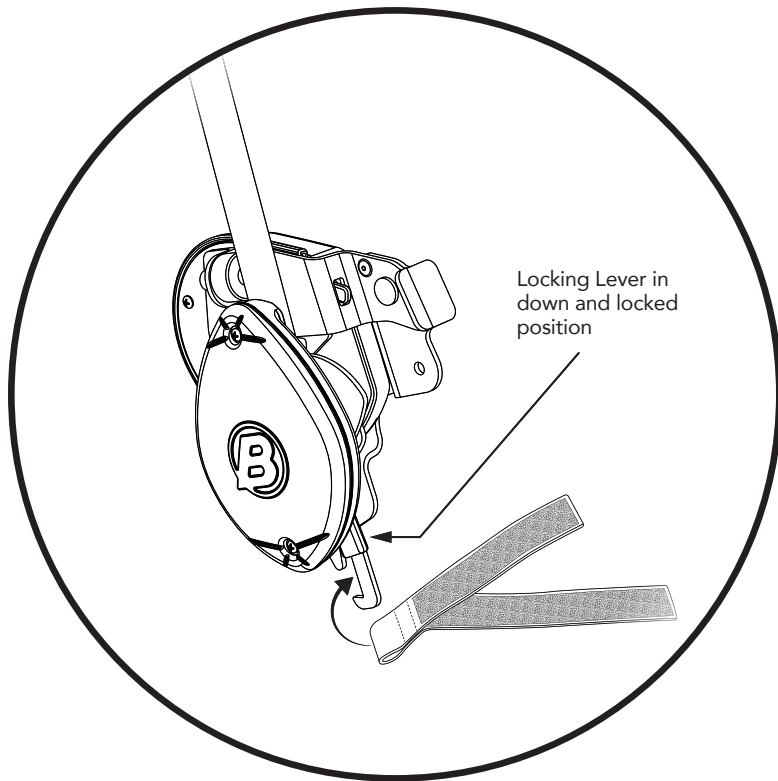

Before attaching the Lift Assist Assemblies and to the Sport Bar Mounting Brackets, make sure that the yellow Locking Lever is in the down and locked position.

Slide the Lift Assist Tie-Down Straps over the hooked tabs at the bottom of each lift assist assembly.

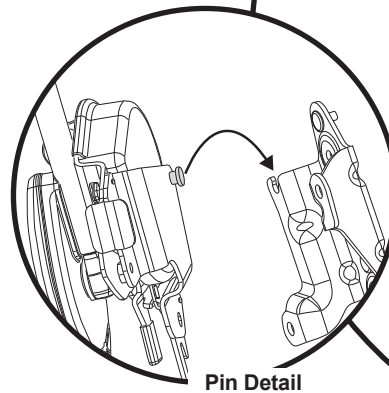
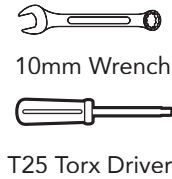

Parts

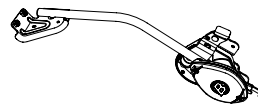

Lift Assist Assembly
Part #589.99 - Left
Part #589.98 - Right (shown)
Qty. 1 of each

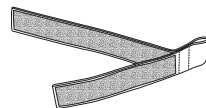

Lift Assist Tie-Down Strap
Part #590.76
Qty. 2



M6 Flanged Nut
Part #591.47
Qty. 4

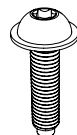

M6x1.0x20 Flanged Torx Screw
Part #533.84
Qty. 4

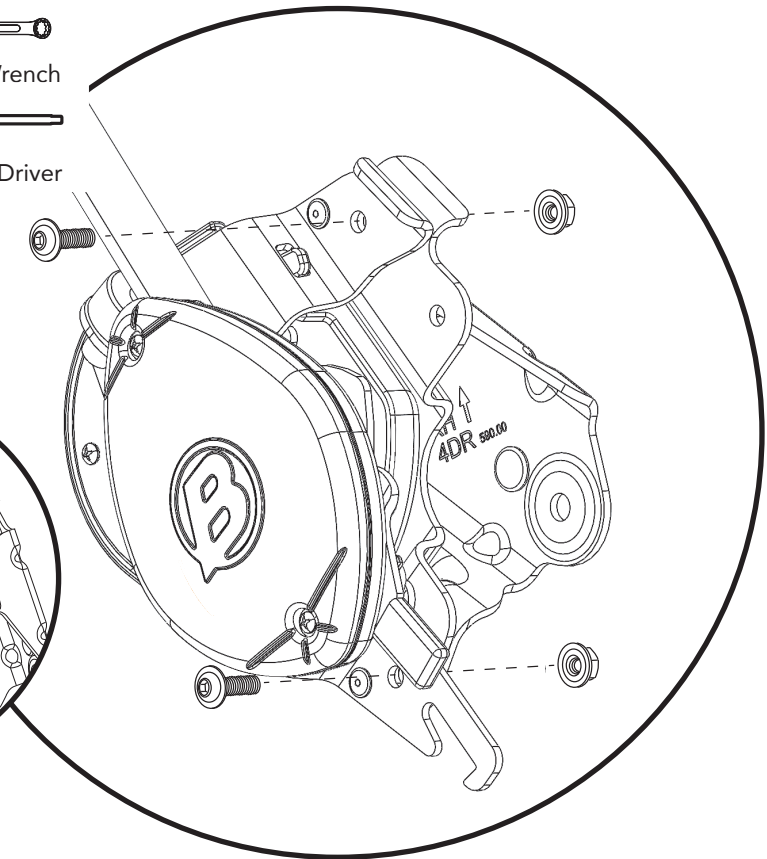

Attach the Right Lift Assist Assembly to the right side Sport Bar Mounting Bracket. Secure with the 2ea. Flange nuts and the 2ea. Flanged Button Head bolts.

NOTE: Be sure the pin in the lift assist goes into the slot in the mounting bracket. (See Detail)

Repeat on the left side of vehicle.

Leave these fasteners only loosely attached at this time. You will tighten them later in the installation process.

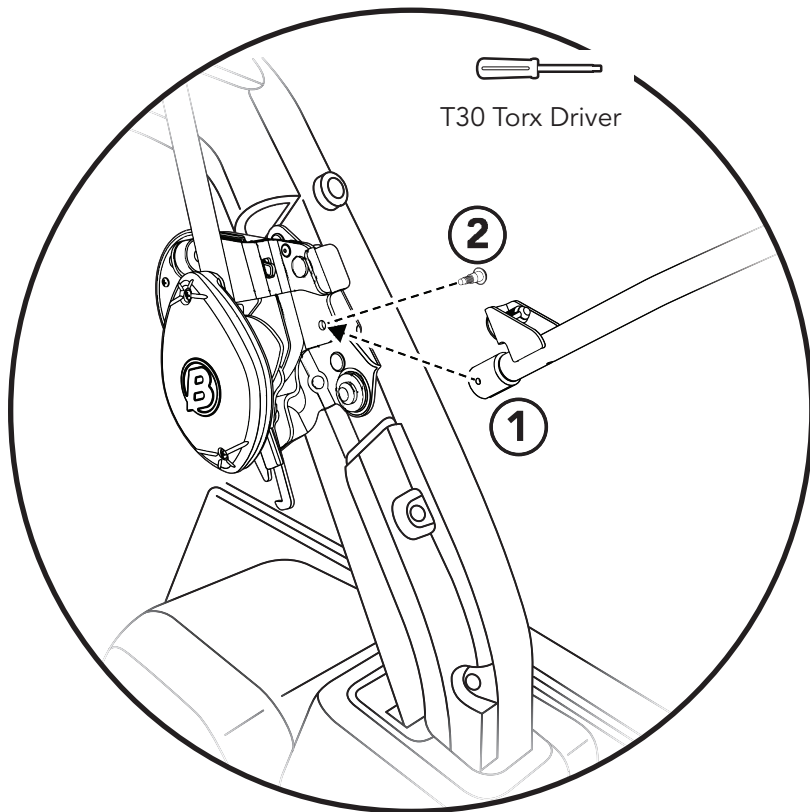

Parts

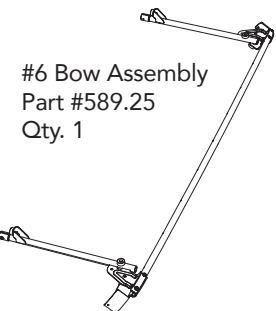

#6 Bow Assembly
Part #589.25
Qty. 1



T30 Torx
Shoulder Screw
Part #308.65
Qty. 2

Attach the #6 Bow to the Sport Bar Mounting Brackets.

- ① Slide the slotted attachment knuckle at the end of each #6 Bow arm over the flange on the top of each Outer Bracket;
- ② Secure with one (1) T30 Torx Shoulder Screw per side.

Parts



#5 Bow
Part #593.55
Qty. 1

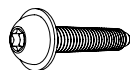

M6x1.0x30
Flanged Torx Screw
Part #533.19
Qty. 8

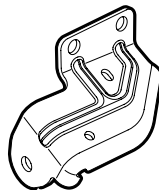

#5 Bow Pivot Bracket
Part #589.19 - Left (shown)
Part #589.18 - Right
Qty. 1 of each

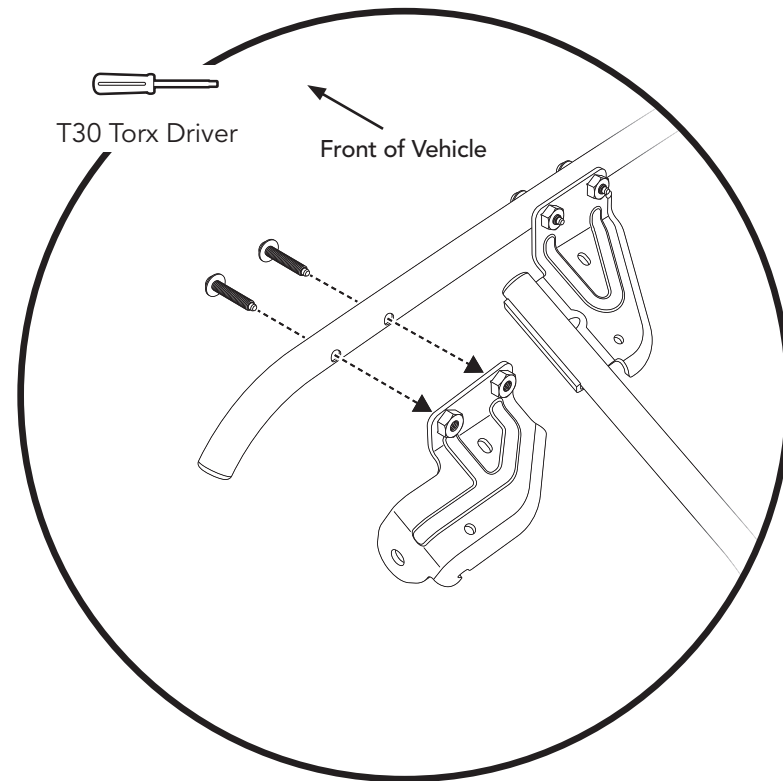
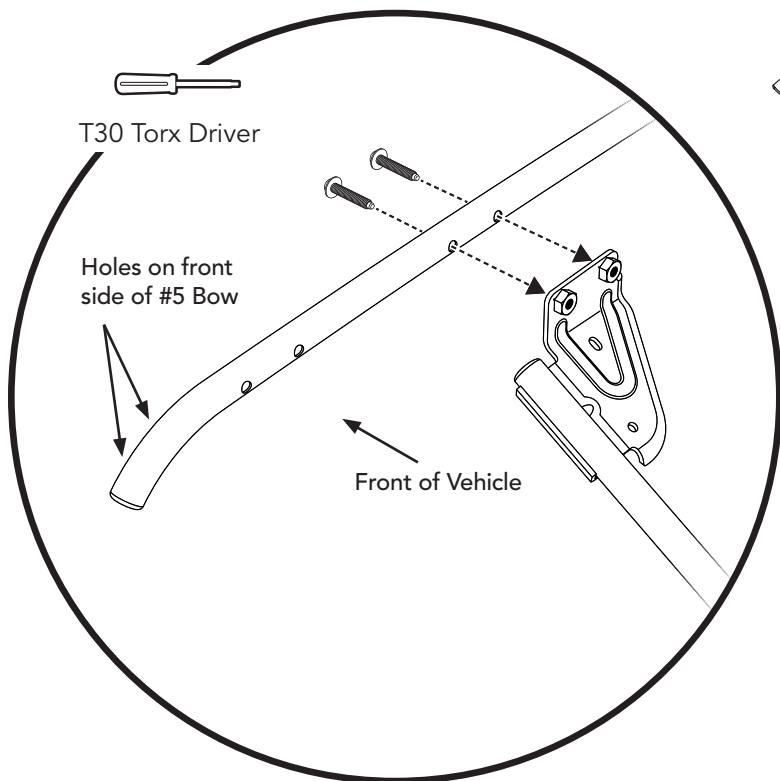

Attach the #5 Bow to the tab on the top of each Lift Assist Mechanism, using two (2) M6x1.0x30 Flanged Torx Screws per side.

NOTE: Make sure the two holes (Closest to the ends) of the #5 bow are facing toward the front of the vehicle.

Attach the #5 Bow Pivot Brackets (left) and (right) to the #5 Bow.

Secure the Pivot Brackets to the #5 Bow using two (2) M6 x 1.0 x 30.0 Flanged Button Head Screws for each bracket.

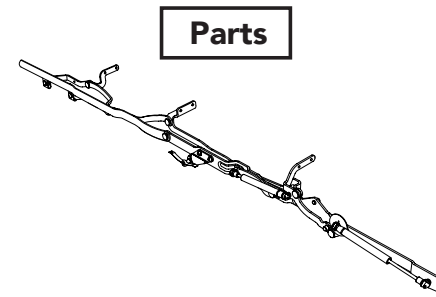
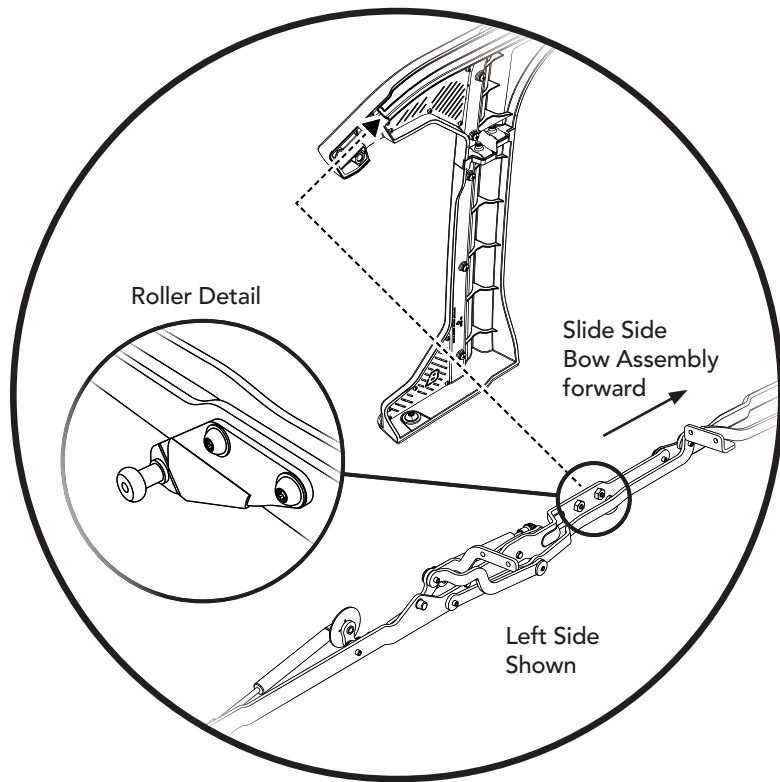

Side Bow Assemblies
Part #585.72 - Right
Part #585.73 - Left (shown)
Qty. 1 of each

Straighten the side bow assemblies then locate the roller on the outside of each side bow assembly. (Right side) and (Left side).

Make sure to orient tabs for attaching roof bows face to the inside.

Insert the roller into the open end of the channel at the rear on the inside of each Rear Door Rail, and slide the Side Bow Assembly forward until it stops.

NOTE: These side bows contain gas struts to assist in the opening and closing the "Sunrider" portion of the top and caution needs to be taken to prevent fingers from getting pinched.

Parts



M8 Shoulder Screw
Part #586.72
Qty. 2



Thick Plastic Bushing
Part #570.42
Qty. 2



Thin Plastic Bushing
Part #532.78
Qty. 2

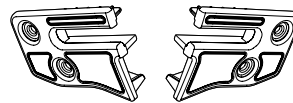

Rear Door Rail Cover Plates
Part #589.48 - Right
Part #589.49 - Left
Qty. 1 of each



M6 x 1.0 x 10mm
Flanged Allen Screw
Part #572.83
Qty. 4

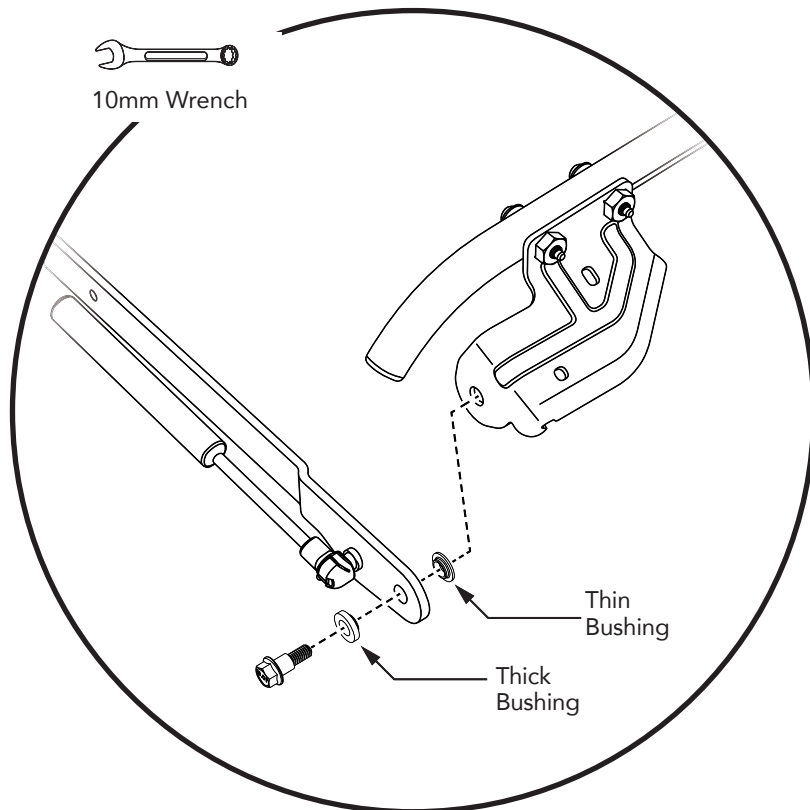

Attach the pivot point at the rear of each Side Bow Assembly to the Pivot Bracket on each end of the #5 Bow.

Secure using one (1) Shoulder Screw, one Thick Plastic Bushing, and one Thin Plastic Bushing per side.

The Thick Plastic Bushing goes to the outside.

Left side shown. Repeat on right side.

NOTE: Make sure the side bow is square to the pivot bracket to allow the bolt to thread into the bow pivot bracket correctly.

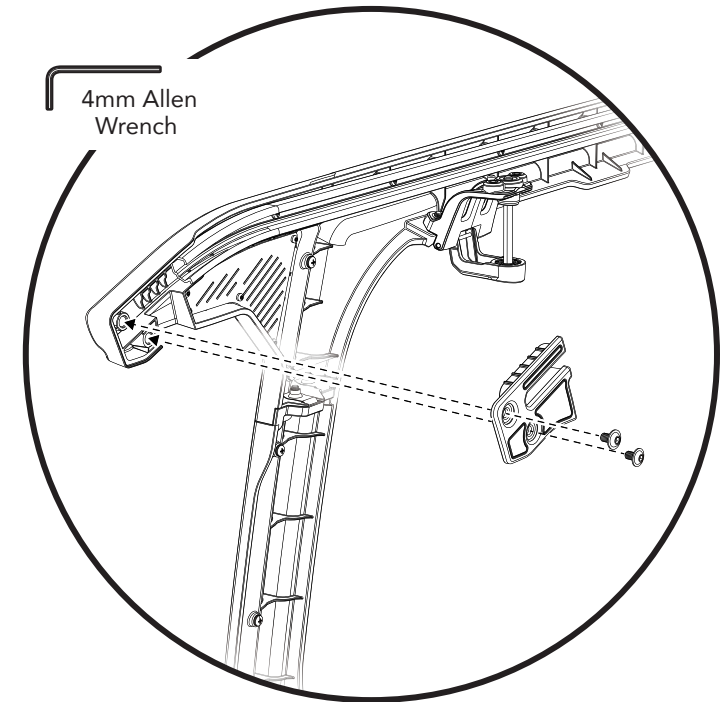

Attach the Rear Door Rail Cover Plates (right) and (left) to each Rear Door Rail Assembly using two (2) screws for each Cover Plate.

Left side shown.

Parts

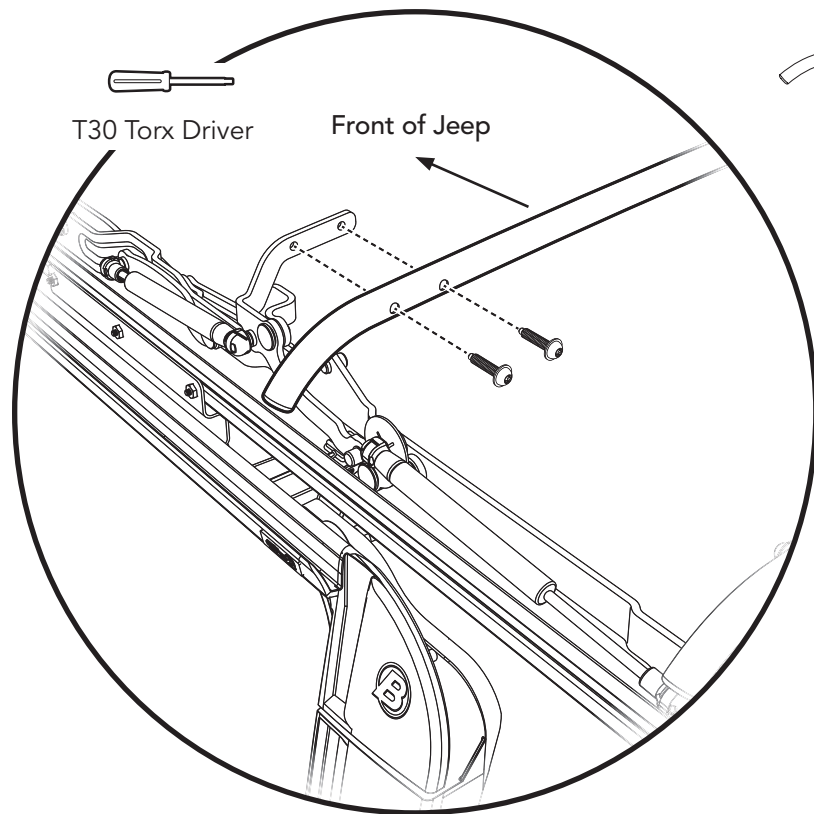

#4 Bow (longer)
Part #583.03
Qty. 1



#3 Bow (shorter)
Part #583.01
Qty. 1

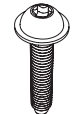

M6x1.0x25
Flanged Torx Screw
Part #535.23
Qty. 8

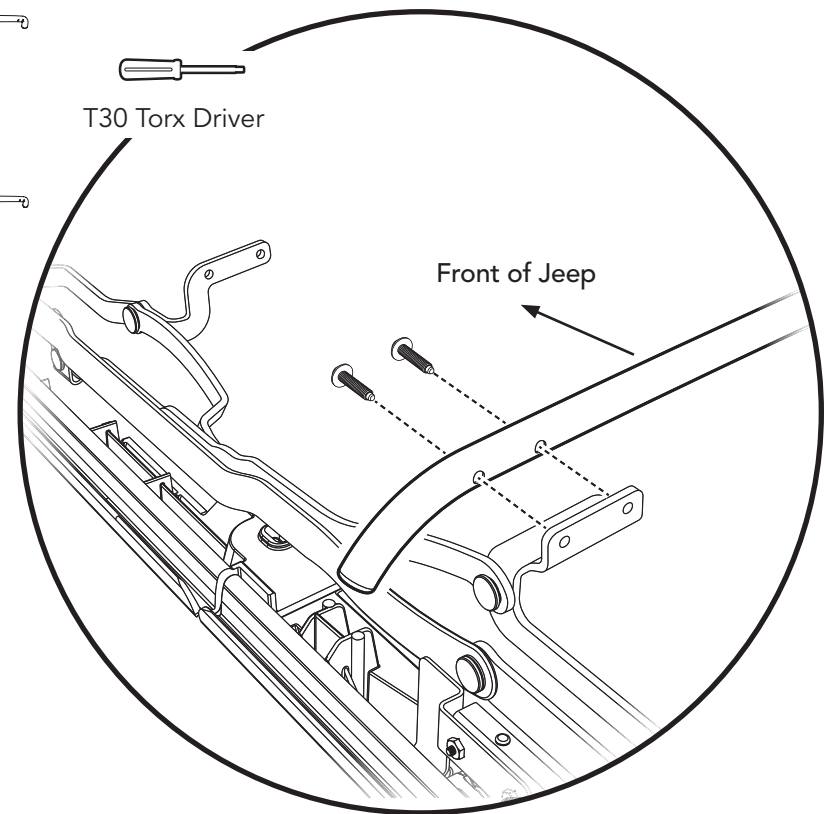

Attach the #4 Bow to the tabs on the Side Bow Assembly (just above the Rear Door Rails), using two (2) M6x1.0x25 Flanged Torx Screw per side.

Attach the #3 Bow to the tabs on the Side Bow Assembly (just above the where the Front Door Rails join the Rear Door Rails), using two (2) M6x1.0x25 Flanged Torx Screw per side.

NOTE: The #4 bow is attached to the rear facing side of the side bow tabs.

NOTE: The #3 bow is attached to the forward facing side of the side bow tabs.

Parts

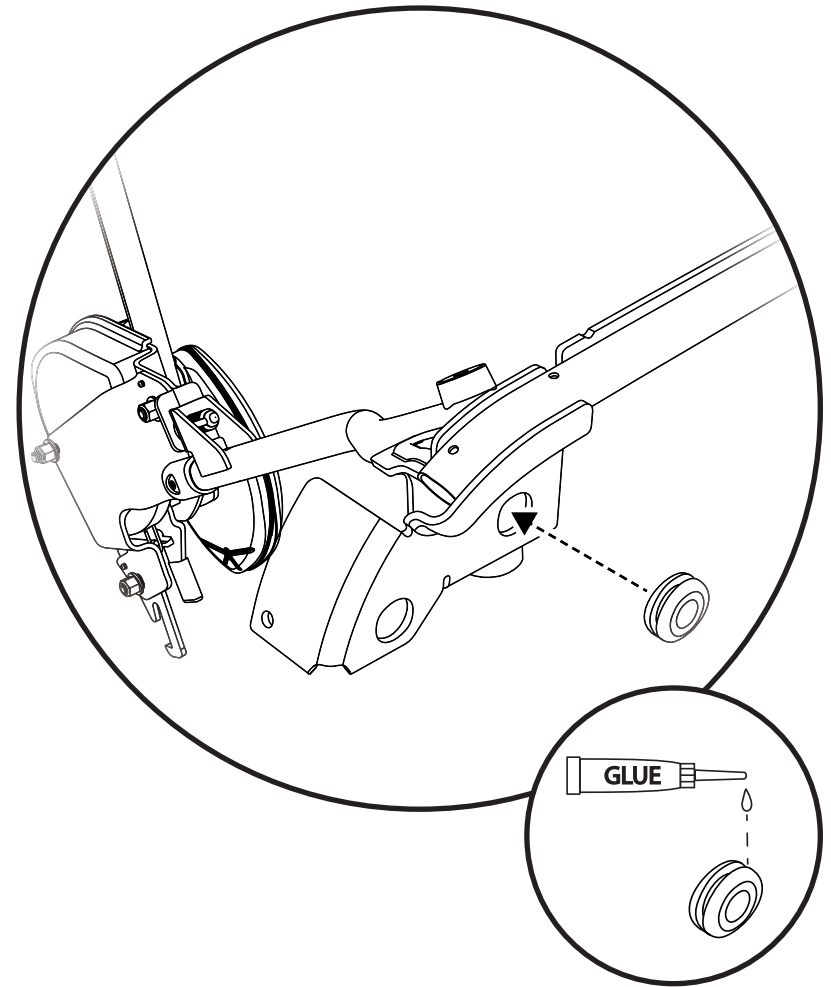
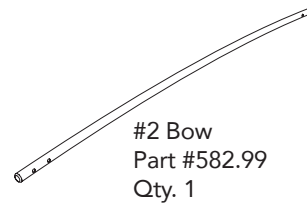
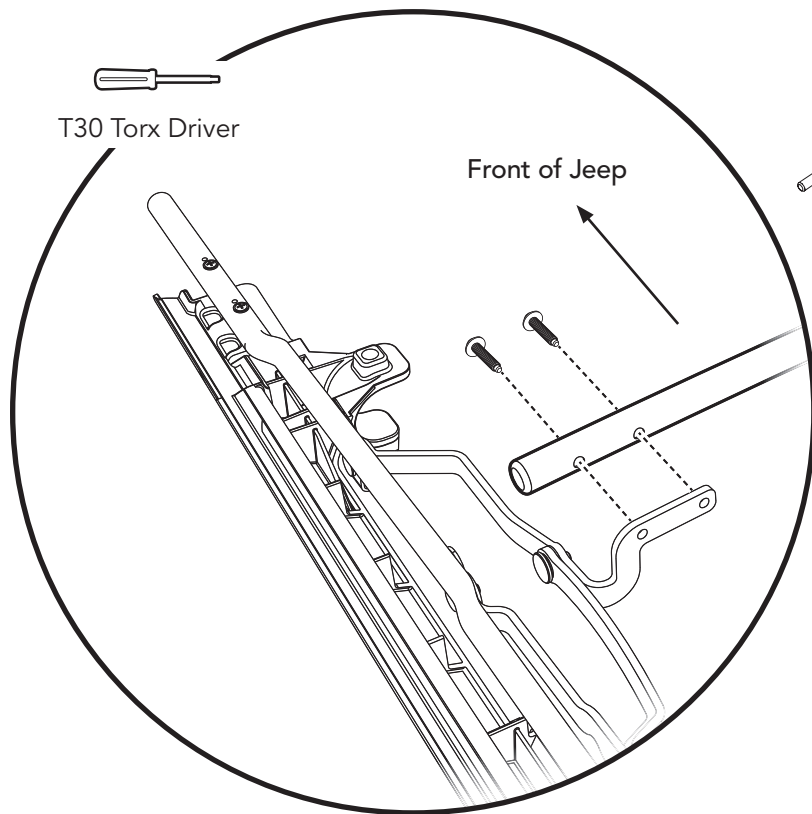

Attach the #2 Bow to the tabs on the Side Bow Assembly, using two (2) M6x1.0x25 Flanged Torx Screws per side.

Note that the #2 Bow attaches to the forward-facing side of the tabs.

Install the Grommets into the inboard holes in the rear-facing flanges at the ends of the #6 Bow.

NOTE: Grommets must be bonded in place with super glue or similar adhesive.

Parts



#1 Bow-Fabric Deck
Qty. 1
(shown without fabric deck)

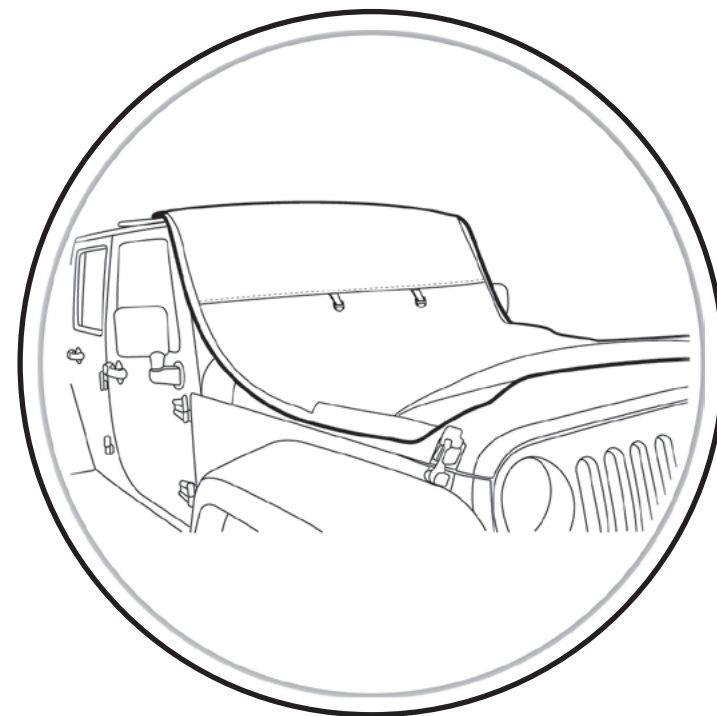
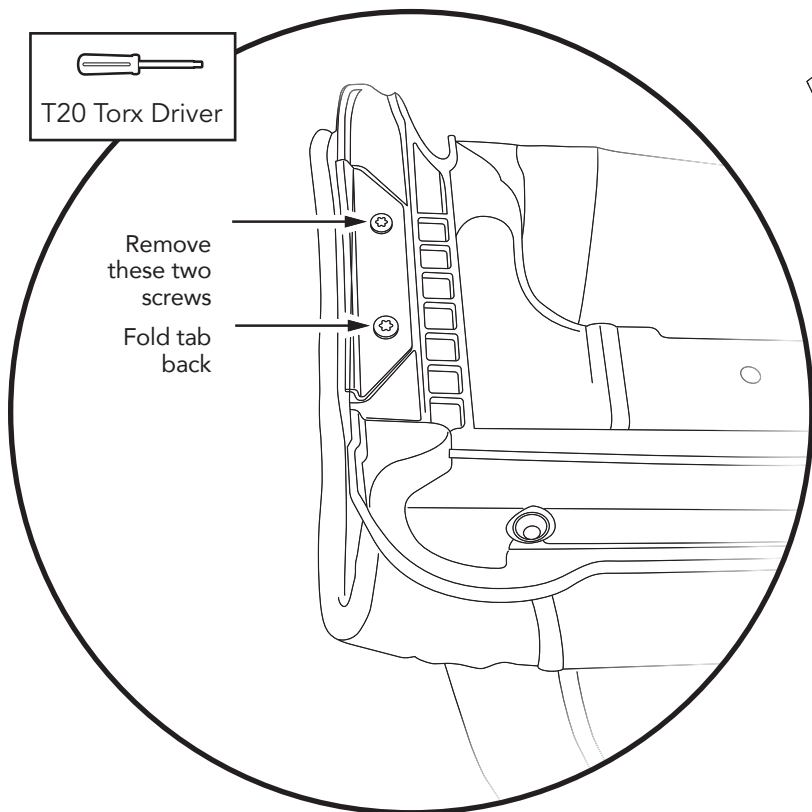

Place the #1 Bow-Fabric Deck on top of the windshield header.

Lay the top fabric across the Jeep hood, with the underside facing up.

On the underside of the #1 Bow-Fabric Deck, remove the two screws on each side that hold down the tabs, and fold each tab back.

Repeat on both sides of the #1 Bow.

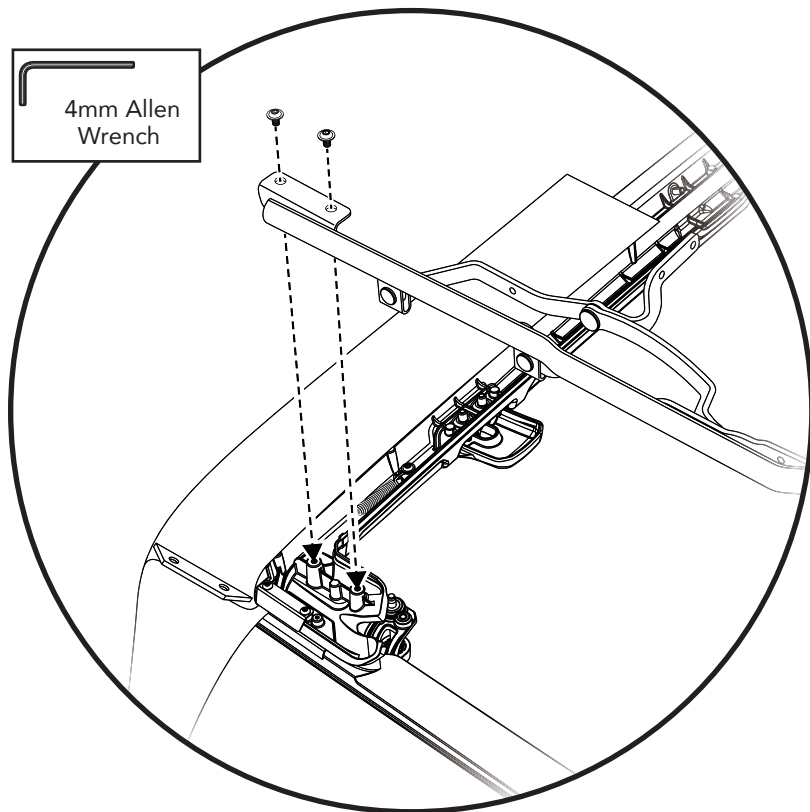

Parts



Side Bow Assembly
 Part #585.72 - Right
 Part #585.73 - Left
 Qty. 1 of each

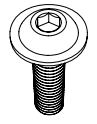

M6 x 1.0 x 10mm
 Flanged Allen Screw
 Part #572.83
 Qty. 4

Attach the front bracket on each Side Bow Assembly (right) and (left) to the #1 Bow-Fabric Deck.

With the Fabric Deck flipped over the Jeep hood, use two (2) M6 x 10 Flanged Button Head Screws on each side to attach the welded bracket to the #1 Bow.

NOTE: You must push the #1 Bow-Fabric Deck as far forward as possible to allow inserting the screws to attach the side bows.

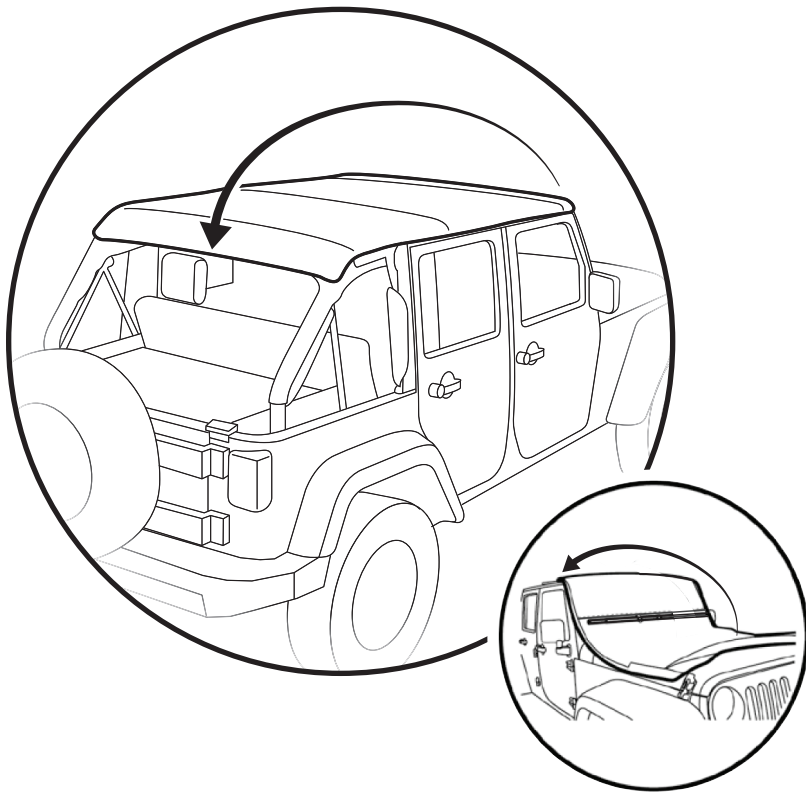

Pull the Top Fabric back across the top of the Jeep and all the installed Bows.

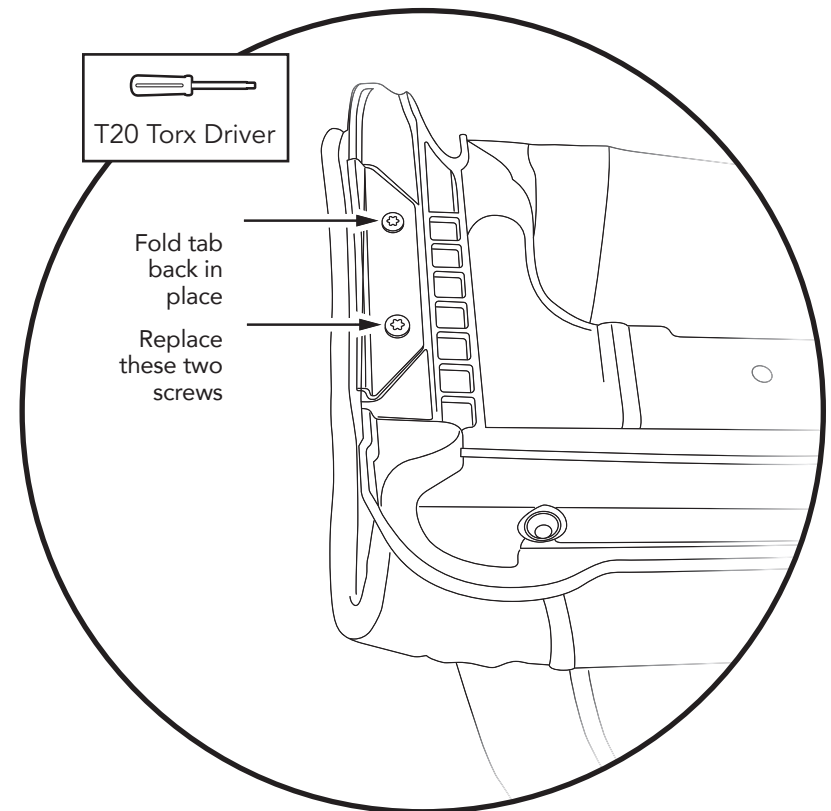

Lift the front of the #1 Bow/Header and fabric to about 45°.

Re-attach the tabs to the underside of the #1 Bow-Fabric Deck using the two (2) screws on each side that you removed in Section 13, step 1.

Parts

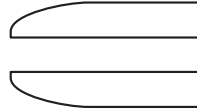

Foam Seals
Part #573.20 (right)
Part #573.21 (left)
Qty. 1 of each

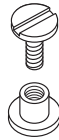

Screw-Binding Barrel
Part #599.01
Qty. 2

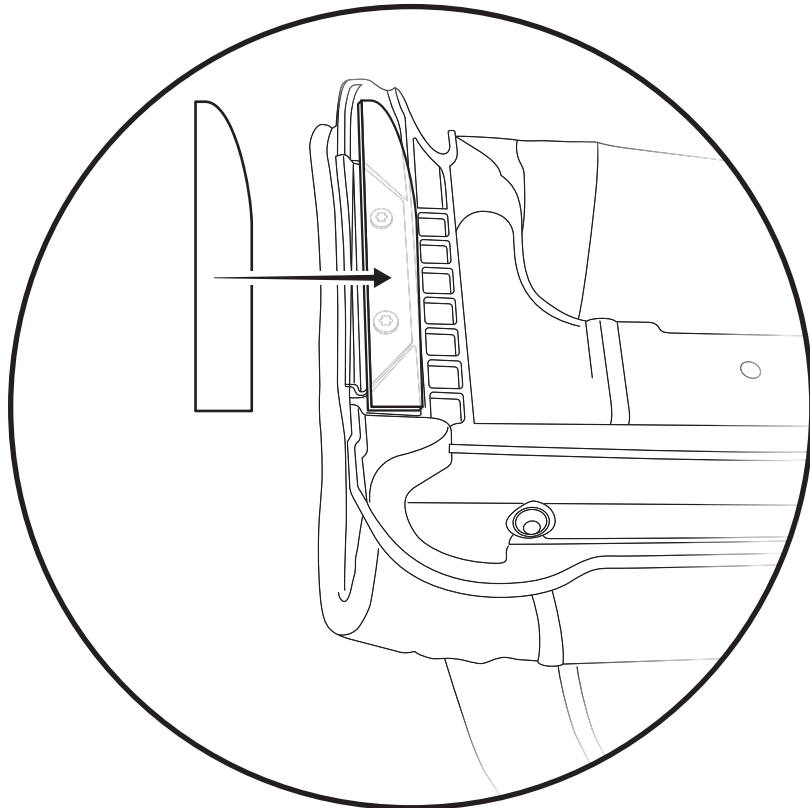

With the front portion of the top folded back, locate the two (2) Foam Seals. Remove the protective liner from the back side of each Foam Seal and place the Foam Seal in the location shown in the diagram.

Repeat on both sides of the Jeep.

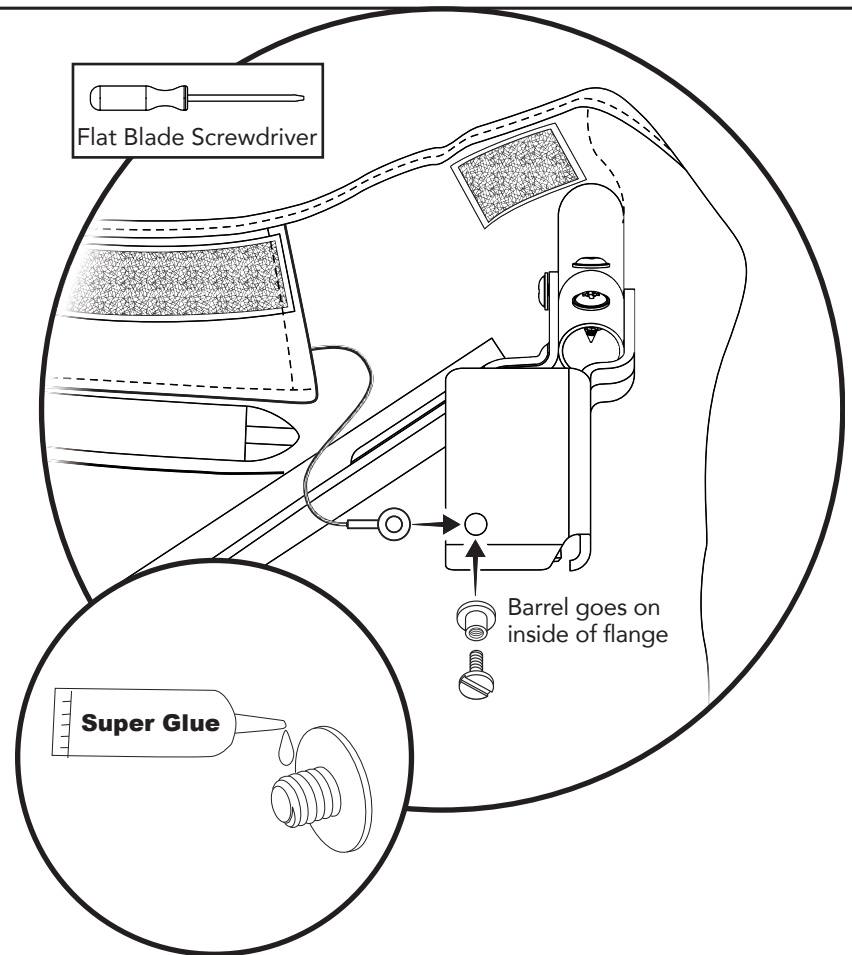

Locate the Cable where it exits the underside of the top near the #6 Bow on each side.

To attach the end of each cable to the #6 Bow Plate; Secure the end of the cable to the hole in the lower corner of the #6 Bow Plate with the screw with Binding Barrel.

NOTE: The Barrel goes on the inside of the #6 Bow flange, and will protude to the outside.it into the barrel.

Apply a small drop of SuperGlue as a thread-locker. Next, loop the eyelet on the end of the cable over the Barrell on the outside of the #6 Bow Plate, getting captured underneath the screw head, as you screw it into the Barrel.

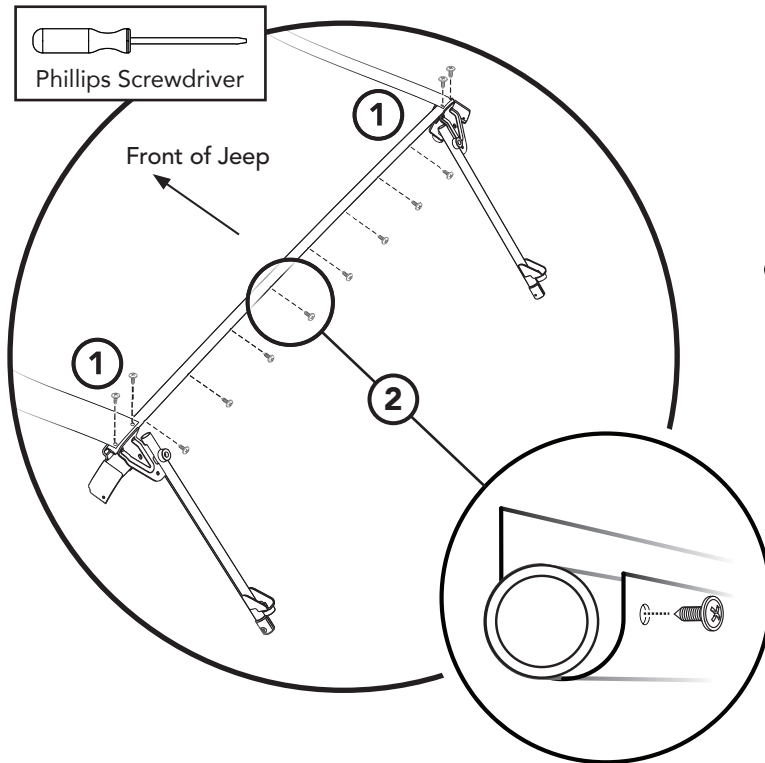

Parts



Sheet Metal
Screw
Part #393.79
Qty. 17

① Secure the rear-facing end of each Stay Strap (attached to the underside of the top fabric) to the top outside ends of the #6 Bow, using two (2) Sheet Metal Screws for each side.

② Attach the fabric flap at the rear underside of the top to the #6 Bow, using nine (9) Sheet Metal Screws.

Wrap the fabric flap around the #6 Bow from back-to-front.

For easier installation, insert the Screws into the pre-punched holes in the flap before attaching to the #6 Bow.

Attach the middle screw first, and work outward from there on each side.

NOTE: Do not attach the window flap to the #6 bow.

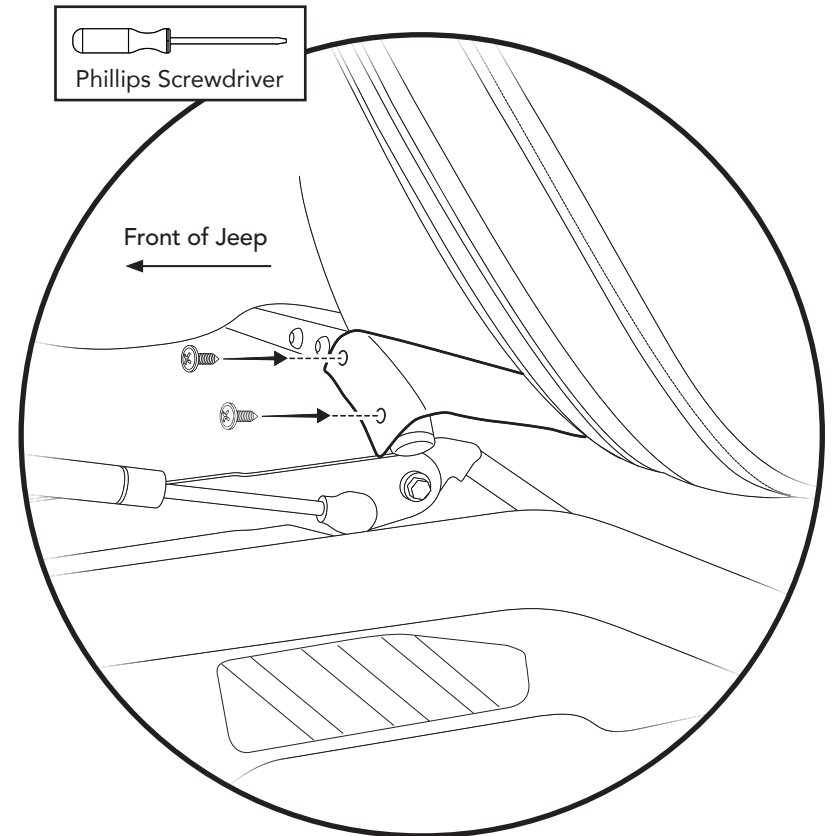

Secure the front-facing end of each Stay Strap (attached to the underside of the top fabric) to the front outside ends of the #5 Bow, using two (2) Sheet Metal Screws for each side.

Lift the #6 Bow up for easier attachment.

Placing the screws into the pre-punched holes in the Stay Strap will make attachment to the #5 Bow easier.

NOTE: You may need to lift the yellow levers to pull the #5 Bow back during the installation of the Stay Straps. * Make sure the yellow levers are back down to the locked position after the Stay Straps have been installed.

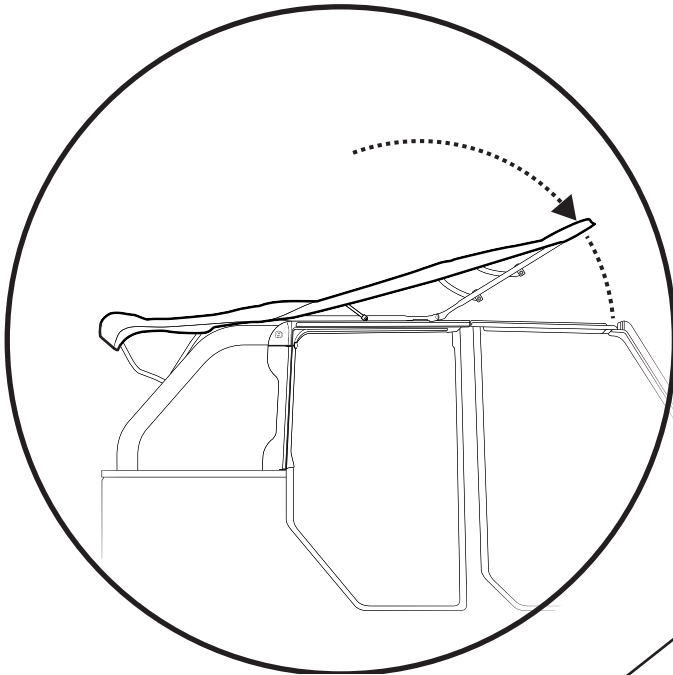

Fold the top forward to close it.

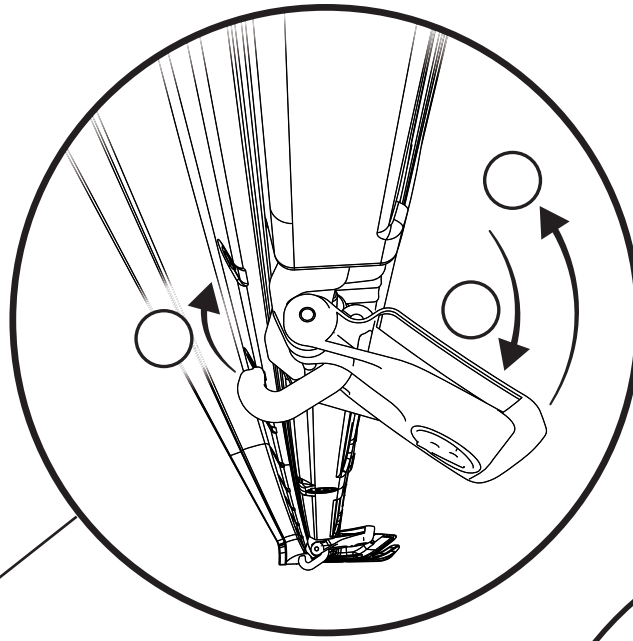

Fold the Sunrider closed and secure both latches to the vehicle's windshield header.

- ① Pivot the latch handle down;
- ② Engage the hook;
- ③ Pivot the latch handle back up.



Now you can tighten the three (3) nuts that secure each Lift Assist mechanism to the sport bar.

Use of a torque wrench to tighten the nuts to 7 ft-lbs is recommended. Due to limited access space, multiple tools may be required, but do not exceed 7 ft-lb torque.

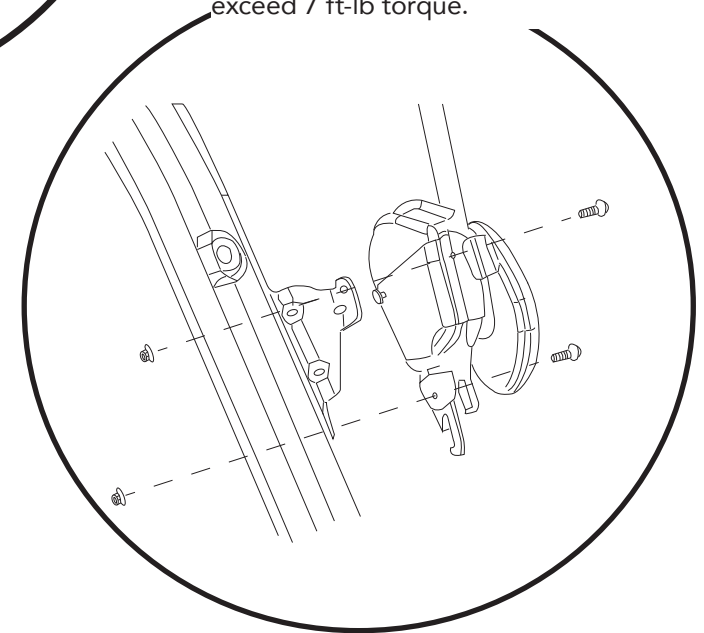

WARNING: Tighten the M6 Flanged Nuts #591.47 to 7ft-lbs. - DO NOT OVERTIGHTEN -

Parts

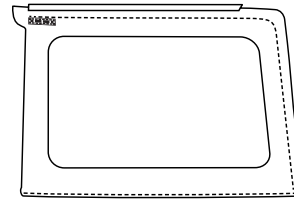

Quarter Windows
Left and Right
Qty. 1 of each

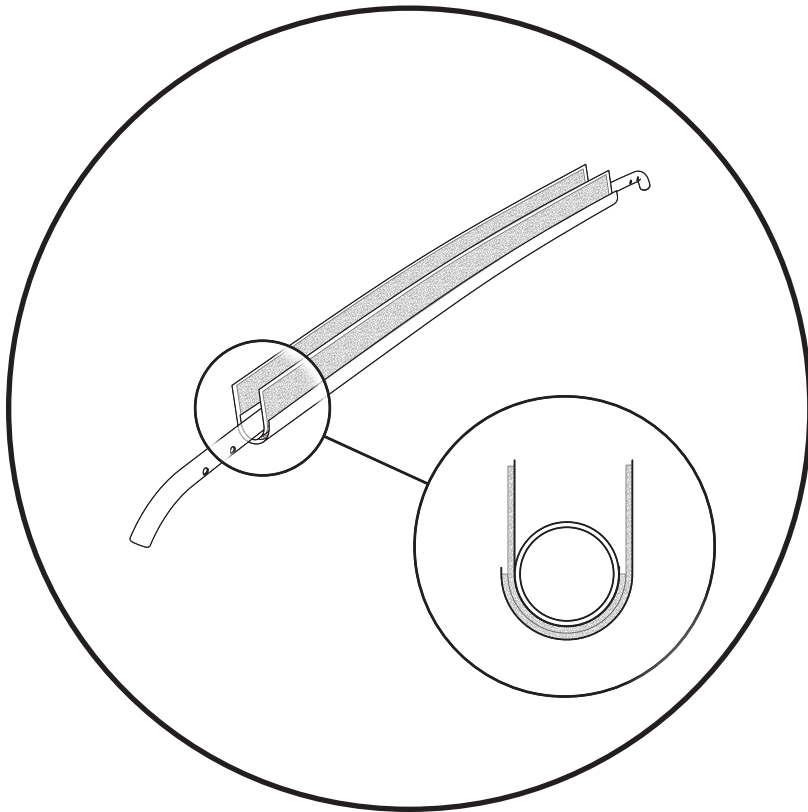

Locate the fabric flap sewn to the inside of the fabric top, just above the #5 Bow.

Wrap these flaps around the #5 Bow so that the Hook side of one flap attaches to the Loop side of the other flap.

Wrap all along the length of the #5 Bow.

Repeat this step, wrapping the #4 Bow, #3 Bow and #2 Bow in this way.

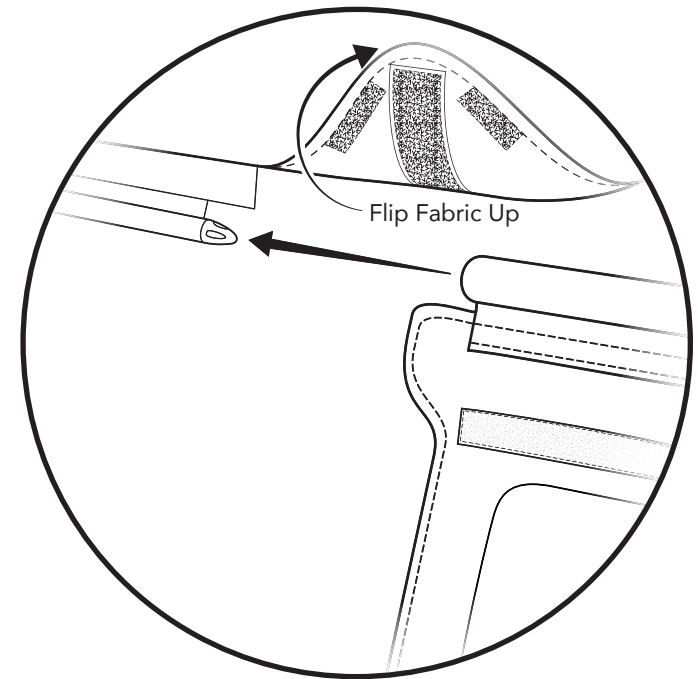

Attach the Quarter Windows.

Locate the plastic channel along the left side edge of the top fabric, behind the left Rear Door Rail.

Lift up the corner of the fabric top for access to the plastic P-extrusion.

Slide the open end of the channel sewn onto the top edge of the quarter window over the sewn-in P-extrusion rail along the bottom edge of the top fabric.

Slide the Quarter Window forward until the front portion of the window is aligned with the rear edge of the Rear Door Rail.

Repeat on the right Side Quarter Window.

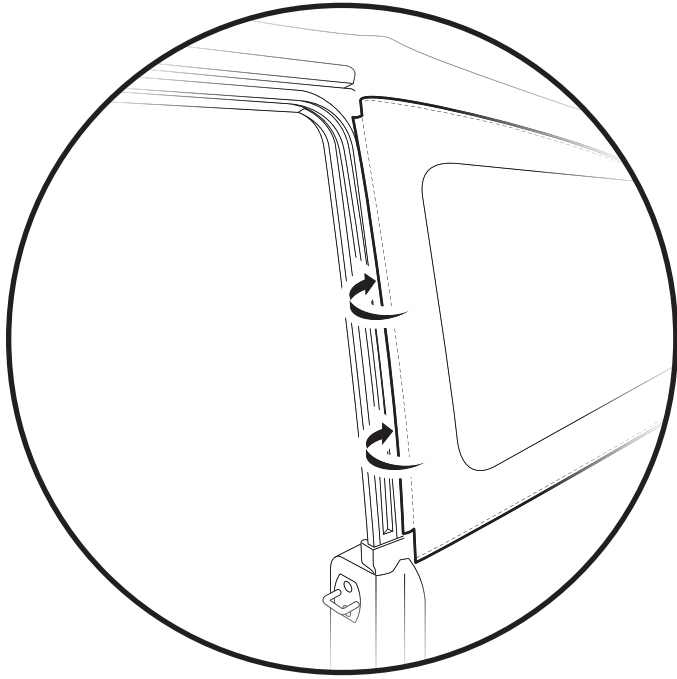

Locate the the sewn-in plastic strip along the front edge of the left Quarter Window.

Tuck this plastic strip into the vertical channel along the outside face of the left Rear Door Rail.

Repeat on the right side of the Jeep.

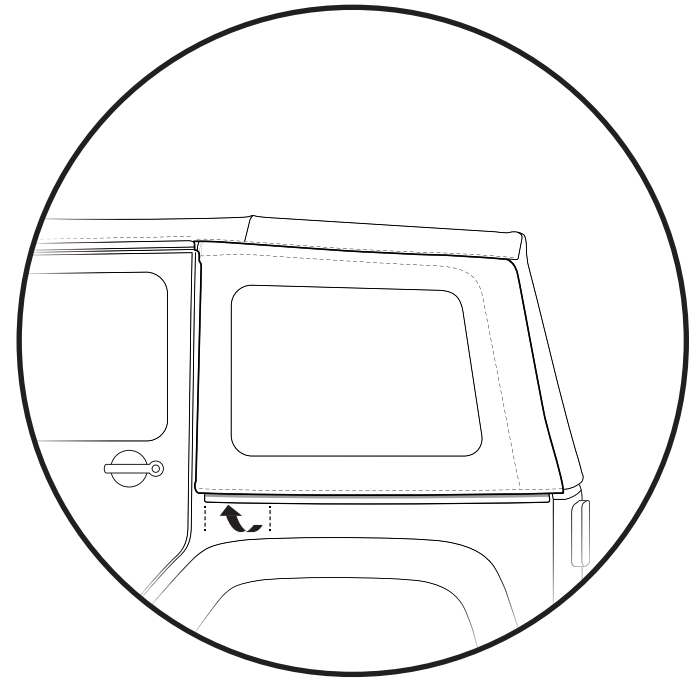

Tuck just the first couple of inches of the plastic strip - along the bottom edge of the left Quarter Window - under the Jeep belt rail, by rolling it up underneath the belt rail.

Repeat on the right Quarter Window.

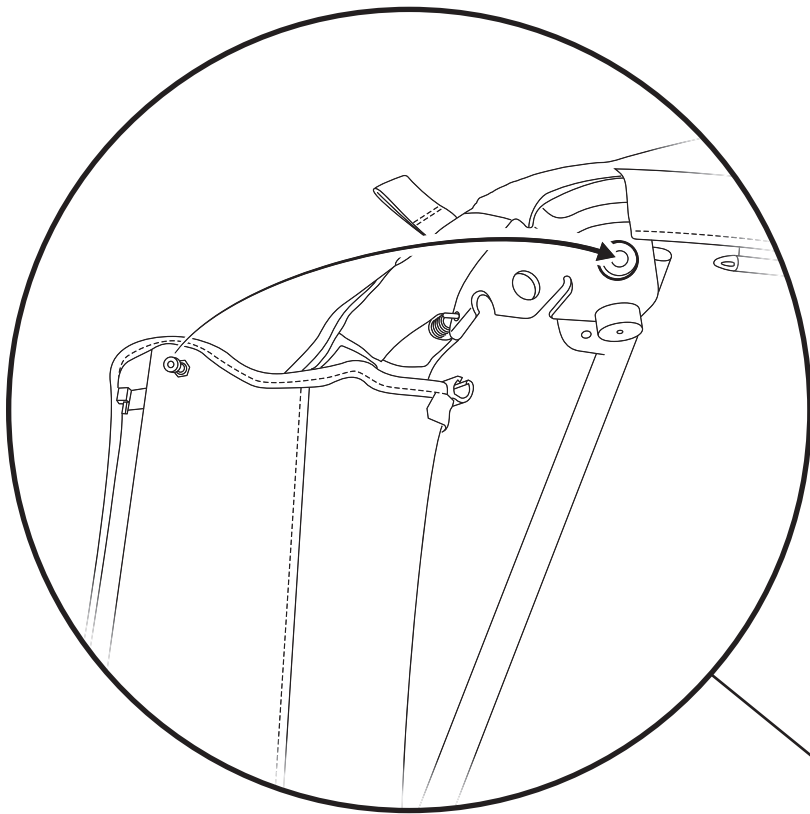

Locate the pin on the inside of the rear top corner of the left Quarter Window.

Wrap the Quarter Window around and insert the pin into the grommet that you installed earlier.

Repeat this step on the right side Quarter Window.

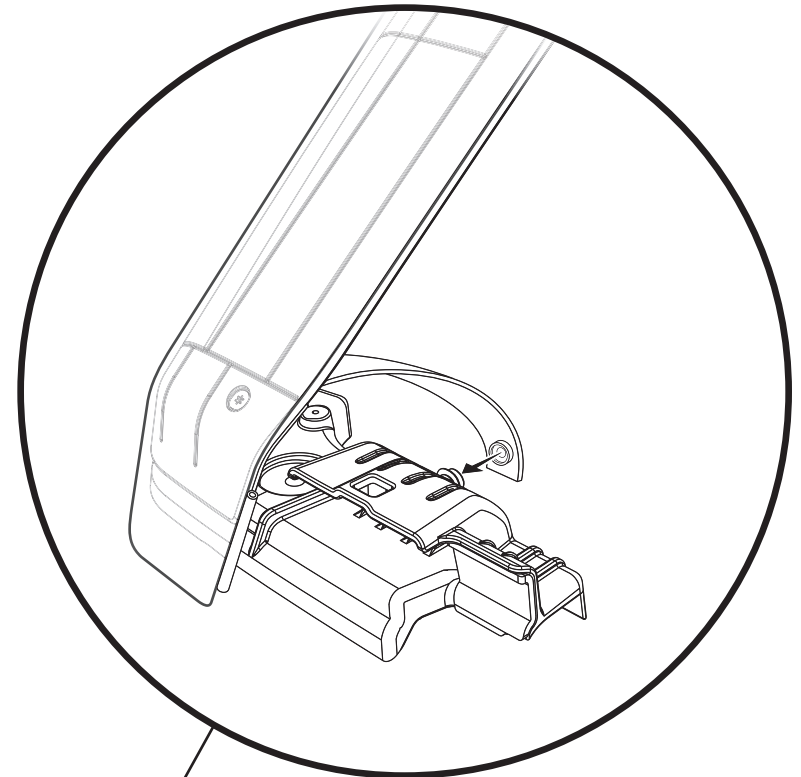

Secure the Quarter Panel Stiffeners to the Tailgate Retainers.

Locate the strap attached to the inside of each Stiffener. Snap the loose end of this strap to the snap located on the inside of each Tailgate Retainer.

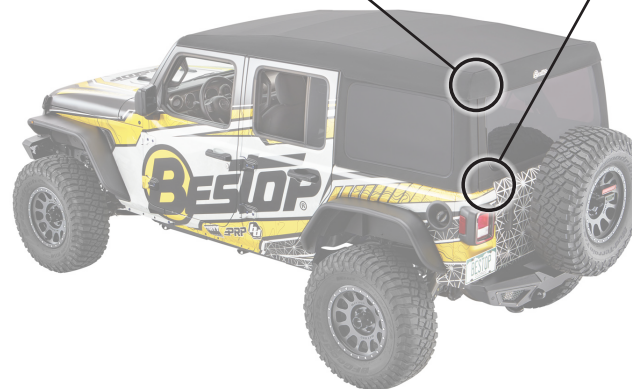

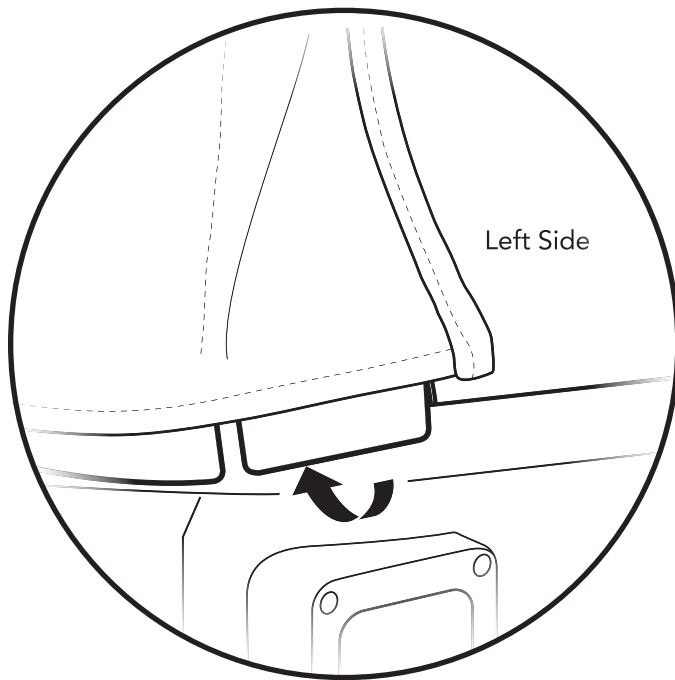

Tuck the plastic tab at the bottom rear corner of each Quarter Window under the Jeep belt rail.

Roll the tab on each side up underneath the Jeep belt rail.

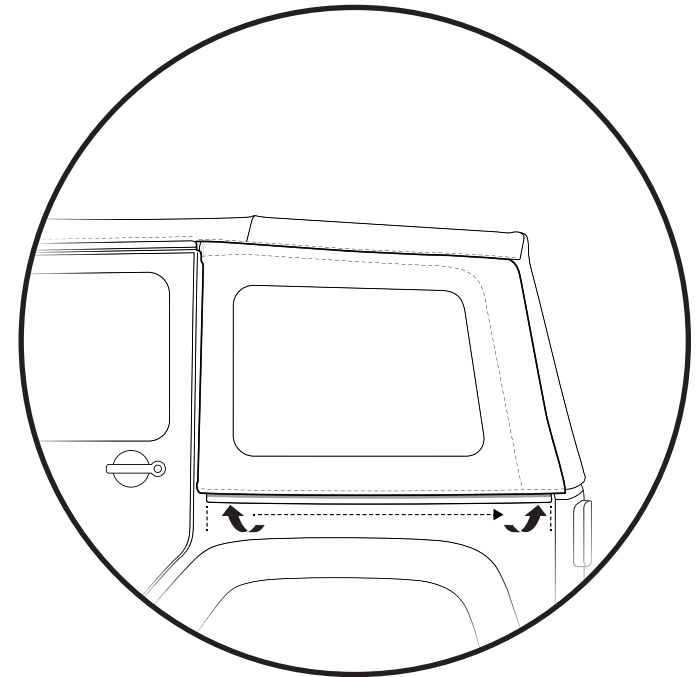

Secure the bottom edge of each Quarter Window.

Tuck the plastic flap along the bottom edge of each window under the Jeep belt rail along the entire length of the flap, from front to back.

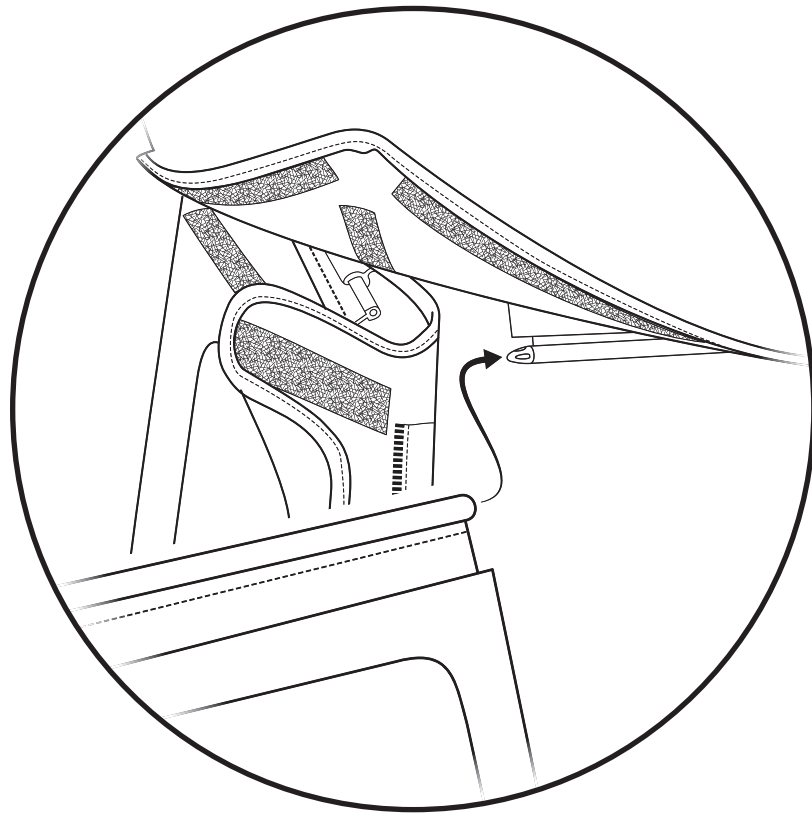

Lift up the rear corners of the Top Fabric to expose the Rear Window attachment tube.

Slide the hollow tip of the sewn-in plastic tube at the top right corner of the Rear Window over the left-side tapered tip of the rail sewn onto the bottom edge of the top fabric, and slide the Rear Window to the right until it meets the right side Quarter Panel Stiffener.

Parts

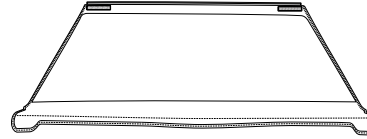

Rear Window

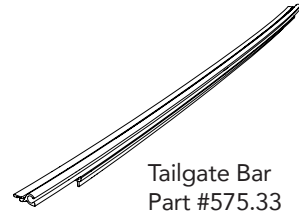
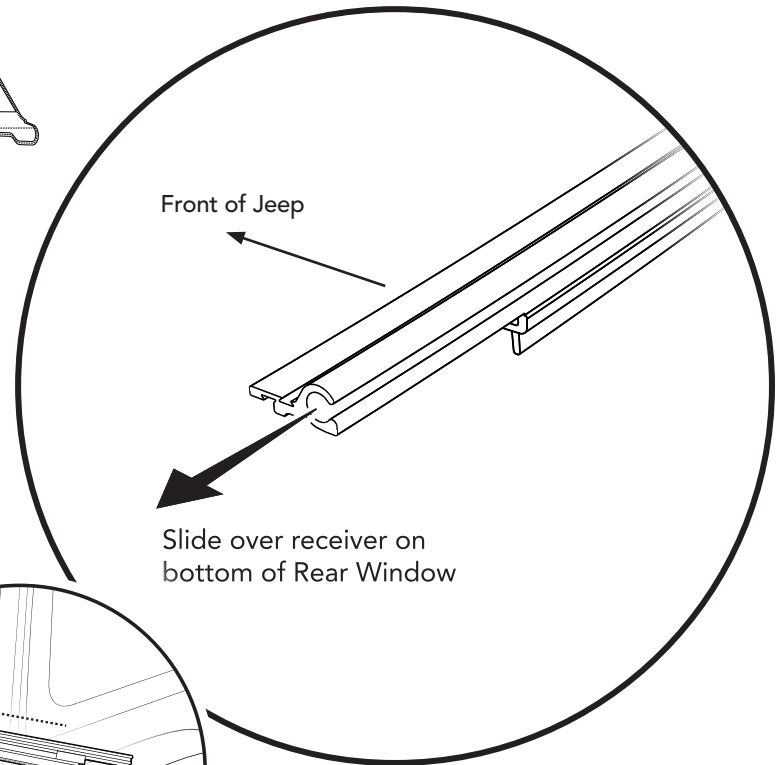
Tailgate Bar
Part #575.33
Qty. 1

Attach the Tailgate Bar to the Rear Window.

Slide the Tailgate Bar channel over the sewn-in receiver rail on the lower inside of the Rear Window.

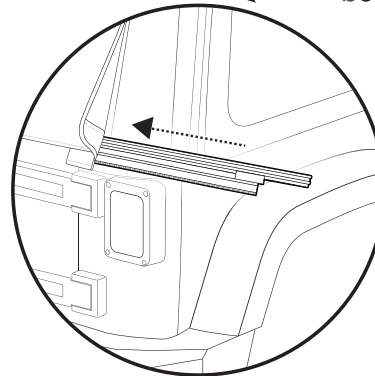

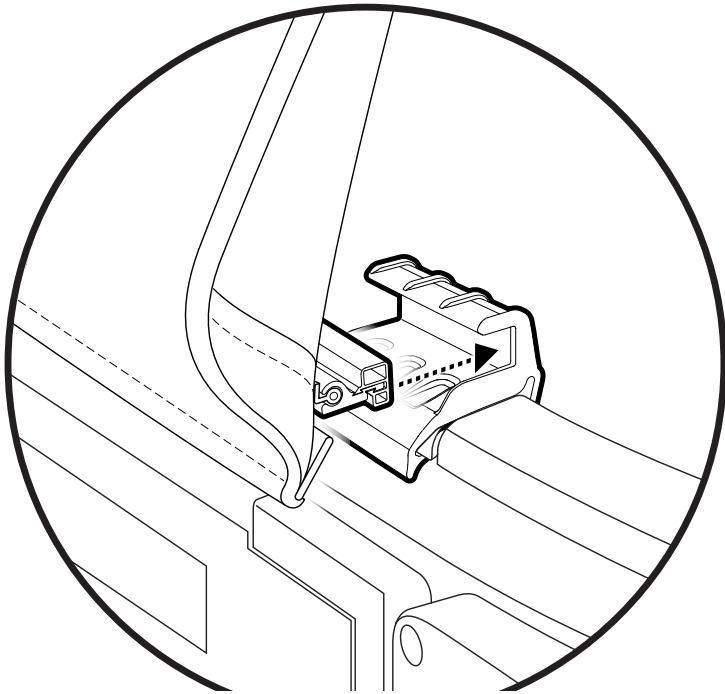

Snap the front edge of the Tailgate Bar into the channel on each Tailgate Bar Retainer.

Repeat for both sides of the tailgate.

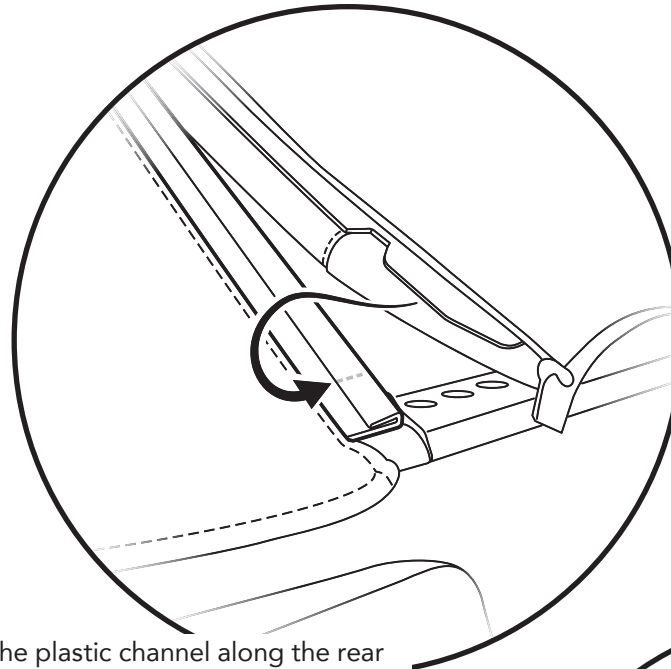

Locate the plastic channel along the rear inside edge of each Quarter Window.

Roll the sewn-in plastic tab on the outside edge of the Rear Window into the open side of the channel, starting either at the top and working down, or at the bottom and working up.

Left side shown above.

Tuck the plastic tab at the bottom right corner of the Rear Window under the Jeep belt rail, by rolling it up underneath the belt rail.

Repeat for the left side.

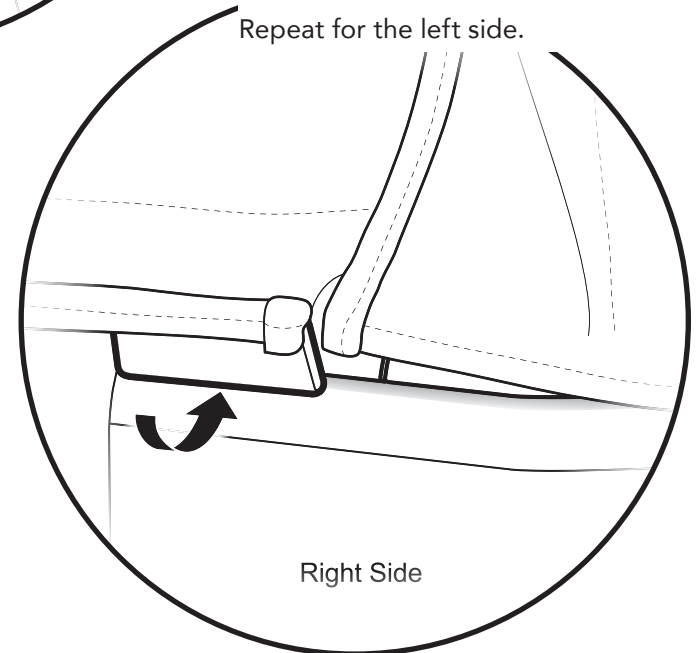

Right Side

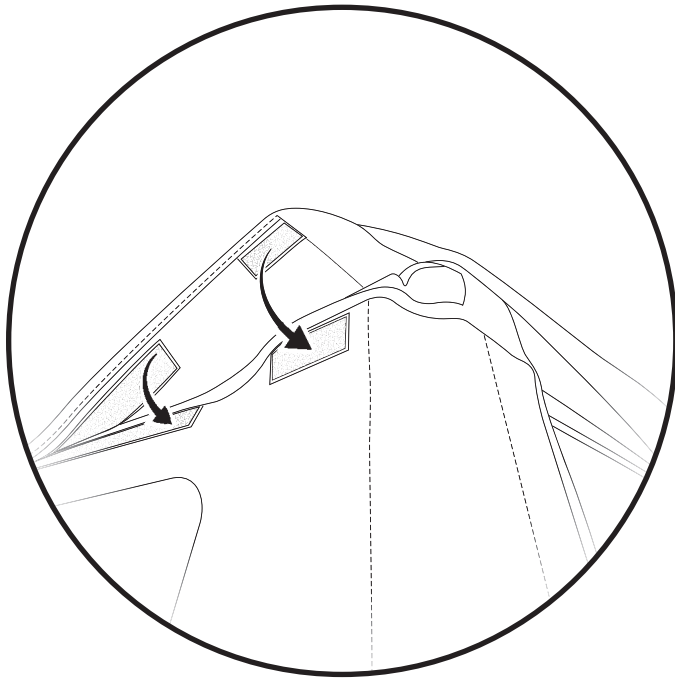

Locate the Hook & Loop strips at the underside of each rear corner and along the rear quarter window overlap of the top fabric.

Snug the rear corners of the top by attaching the Hook & Loop strips on the underside of the top fabric to the strips along the top edges of the Quarter Window and corners.

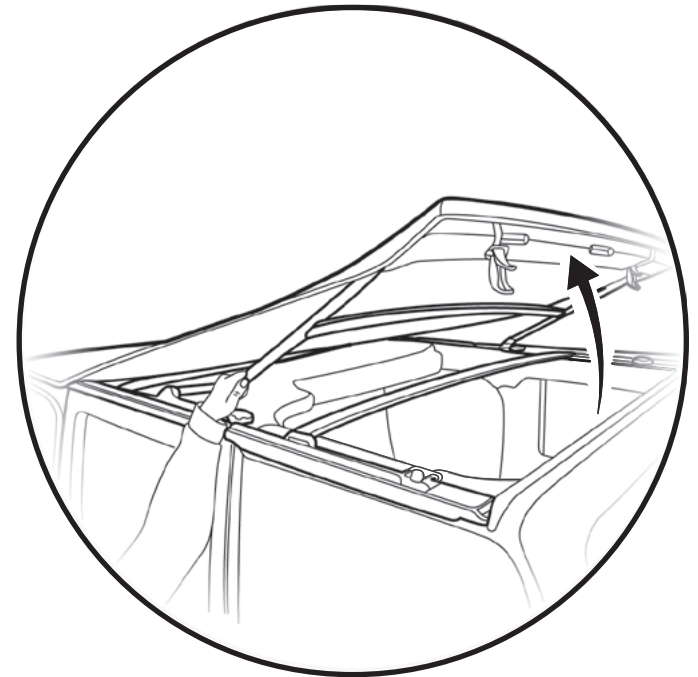

Once the full installation is complete, release the header latches and put the top into the Sunrider mode, to allow the top to stretch and normalize for a while before removing windows or folding the top down.



Care and Maintenance of your Bestop Product

Your Bestop product is made of the finest materials available. To keep it looking new and for the maximum possible wear, it will need periodic cleaning and maintenance.

Fabric: The fabric should be washed often using soap, warm water and a soft bristle brush. Rinse with clear water to remove all traces of soap. Bestop recommends using Bestop Cleaner (part no. 11201-00) and Bestop Protectant (part no. 11202-00) for Vinyl fabric and Bestop Twill Protectant (part no. 11207-00) for Twill fabric. Bestop Cleaner and Bestop protectant are specially formulated to provide a total cleaning and protection system. Bestop Cleaner safely removes the toughest stains, will not harm vehicle finishes, is biodegradable and environmentally friendly. Bestop Protectant protects against UV-fading, cracking and hardening, and repels dust, grease, dirt and mildew.

Windows: Keep windows clean to avoid scratching. DO NOT use a brush on the windows! Wash with a water-soaked cloth or sponge and a mild dishwashing detergent. Bestop recommends Bestop Vinyl Window Cleaner (part no. 11203-00), which safely cleans and protects vinyl windows and helps prevent UV damage. NEVER WIPE THE WINDOWS WHEN THEY ARE DRY. Be careful when cleaning snow or frost from the vinyl windows since they are easily scratched and may crack at low temperatures. DO NOT roll the sides or rear window in cold weather. The windows become stiff and will crack. Cracks caused by misuse in cold temperatures are not covered under warranty.

Water: Seeping through at the seams may be stopped by applying 3-M Scotchgard® on the inside of the seams.

Snaps: Keep snaps cleaned and lubricated with silicone to help prevent snaps from sticking to the studs. If a snap does become stuck to a stud, use a screwdriver and GENTLY pry apart to prevent permanent damage to the snap or the top fabric.

Zippers: Keeping zippers cleaned and lubricated with Bestop's Zipper Cleaner (part no. 11206-00) will help prevent damage and keep the zippers in smooth working condition. If a zipper opens behind the slider, the slider may have been spread apart. This problem can usually be repaired by using an ordinary pair of pliers to bring the sides back into parallel. Return slider to the end of the zipper in the normal Open position. Squeeze lightly at first and test the zipper. If the zipper continues to remain open squeeze more firmly with the pliers and try the zipper again. Repeat this procedure until the zipper operates correctly.

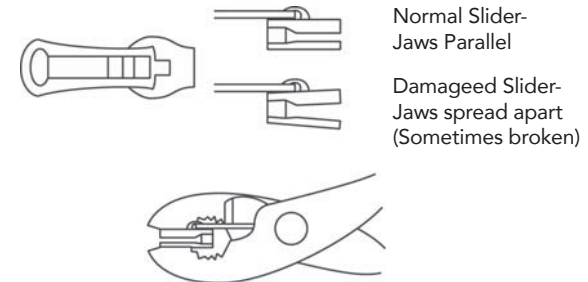

For Bestop Warranty Information, Please go to;
<https://www.bestop.com/help/warranty-information/>

