









Installation Instructions Supertop NX Twill

Vehicle Application:
Jeep® TJ Wrangler 1997-2006
Part Number 54820

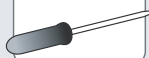
INSTALLATION TIME	SKILL LEVEL
 3 Hours	 2 - Moderately Easy



TOOLS			
 Power Drill 1/8" Bit	 Phillips Screwdriver #1, #2 & #3	 Torx Wrench T30 and T40	 Silicone Sealant
 Adjustable Wrench	 Safety Glasses		

Installation Tips

Before you begin installing this assembly, read all instructions thoroughly.

For a smooth fit:

For ease in installation, the product should be installed at temperatures above 72° F. Below this temperature, the fabric may contract an inch or more, making it difficult to fit to the vehicle. It is normal for fabric to contract and wrinkle when stored in the shipping carton. Within a few days after installation, the fabric will relax and the wrinkles will disappear.

 **CAUTION** Safety glasses should be worn at all times while installing this product.

 **WARNING** This product is designed primarily to enhance the appearance of the vehicle and to shield the occupants from ordinary weather conditions. Do not rely in any way on the components of this product to contain occupants within the vehicle, or to protect against injury or death in the event of an accident. This product will not protect the occupants from falling objects. Never operate the vehicle in excess of manufacturer's specifications.

WEAR SEAT BELTS AT ALL TIMES

Read and follow, precisely, all installation instructions provided when installing product. Failure to do so may result in a poor fit and could place occupants of the vehicle in a potentially dangerous situation.



Installation Instructions

Supertop NX Twill

Vehicle Application:
Jeep® TJ Wrangler 1997-2006
 Part Number 54820

Fabric Top	Qty - 1
Quarter Window, Right	Qty - 1
Quarter Window, Left	Qty - 1
Rear Window	Qty - 1

Parts List and Hardware Identification

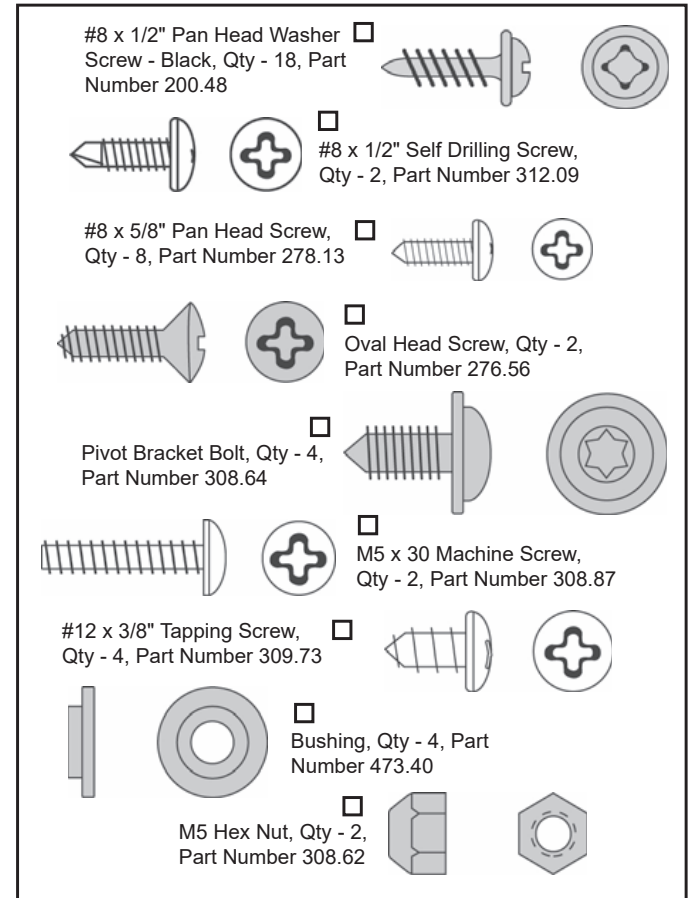
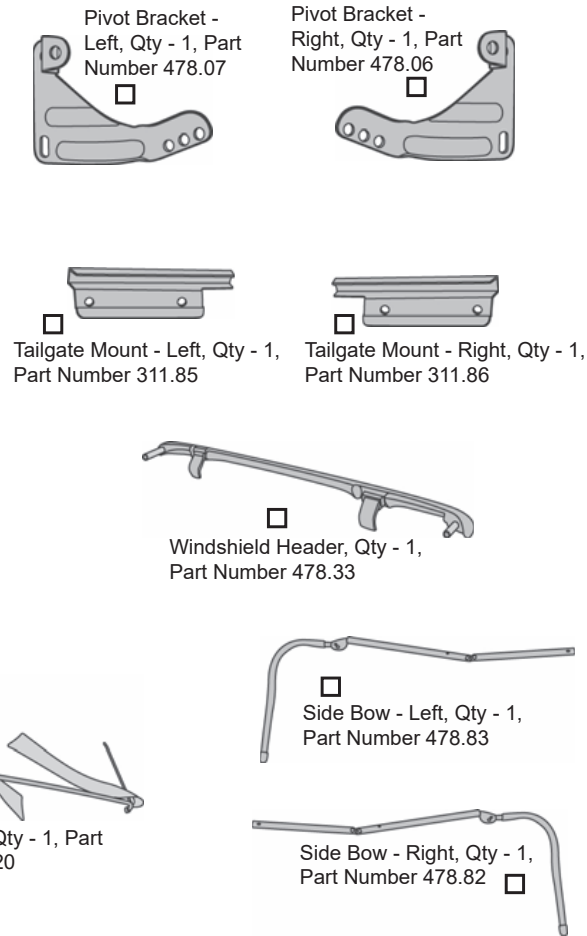
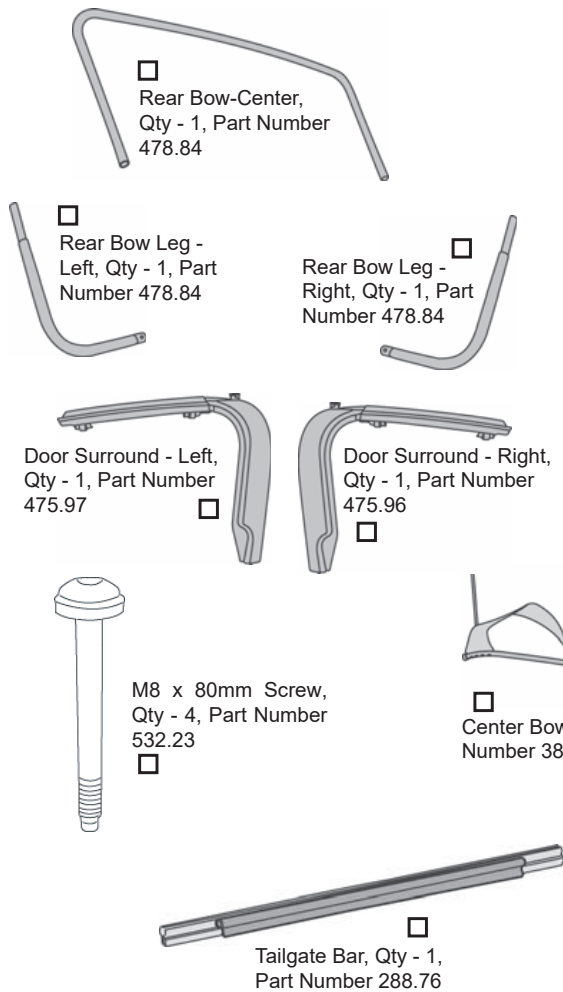



Installation Instructions Supertop NX Twill

Vehicle Application:
Jeep® TJ Wrangler 1997-2006
Part Number 54820

1 Assemble Rear Bow

Orient the Rear Bow Legs with the knobs in the pivot knuckles toward the inside. Slide the Rear Bow Legs and Center section together, aligning the pre-drilled screw holes. Install a #8 x 1/2" Self Drilling Screw, from the parts kit, in each leg.

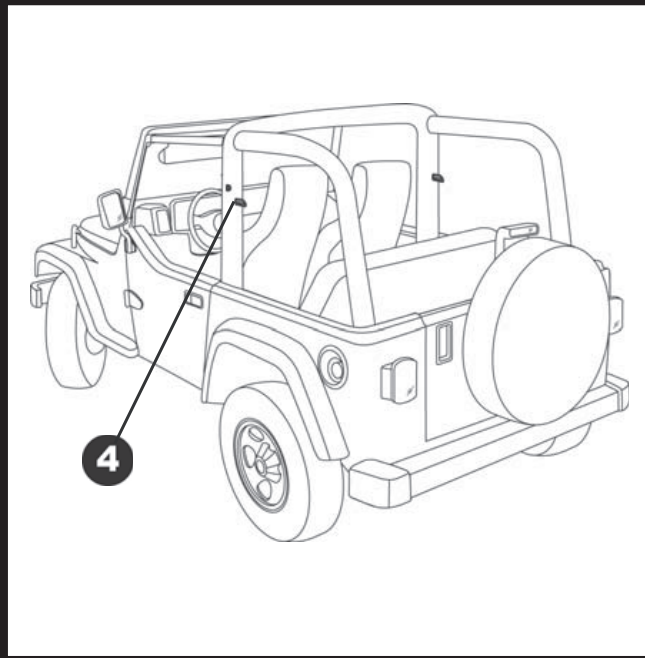
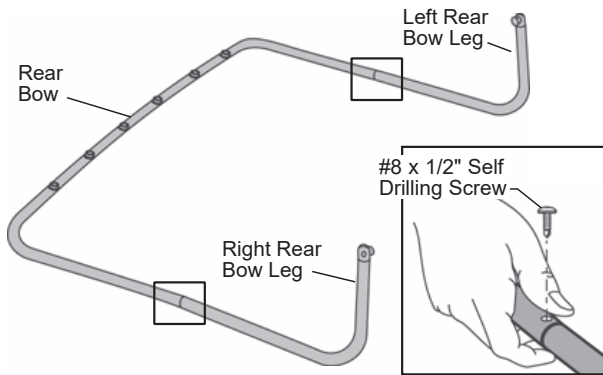

4 Mount Pivot Brackets on Sport Bars

Unzip the vertical padded cover over the sport bar and pull the pad away from the bar to expose the bracket location holes. Orient the Pivot Brackets over the existing holes in the sport bar and install them with the Pivot Bracket Bolts (two bolts per bracket). Zip the padded cover closed.

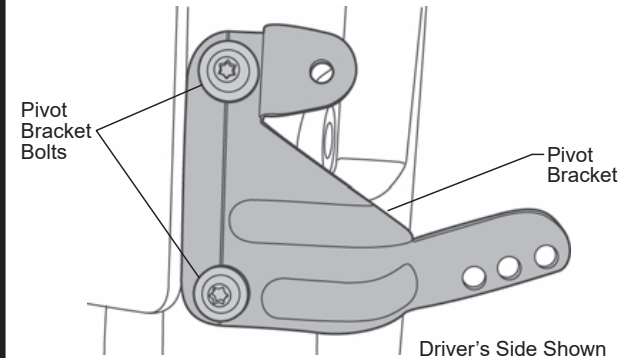

2 Assemble Side Bows to Header

Orient the Side Bows with the knobs in the pivot knuckles toward the outside and the bend pointing up. Slide the other end over the section of tube and into the Header. Install the #12 x 3/8" Tapping Screws, one on each side of the bow, on each side of the header (4 screws). Place a drop of Loctite on the threads of each screw before installing.

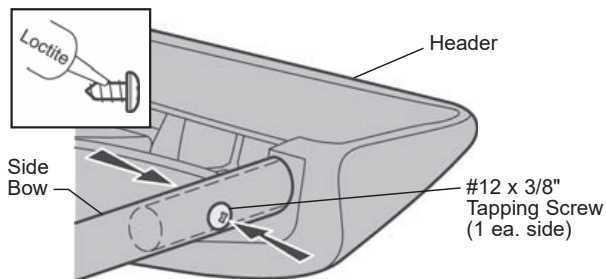

3 Secure Center Bow to Side Bow / Header Assembly

Locate the Center Bow with the fabric Stay Pads attached. Lay the bumpers of the Center Bow on top of the Side Bows and align the holes in the Center Bow with the holes in the Side Bows. Push an M5 x 30 Machine Screw through the Side Bow from the outside. Install a Bushing with the shoulder facing away from the Side Bow. Slide the rod of the Center Bow over the screw and install a second Bushing with the shoulder facing into the hole in the Center Bow. Install an M5 Hex Nut. Tighten the assembly so that the Center Bow is allowed to rotate freely.

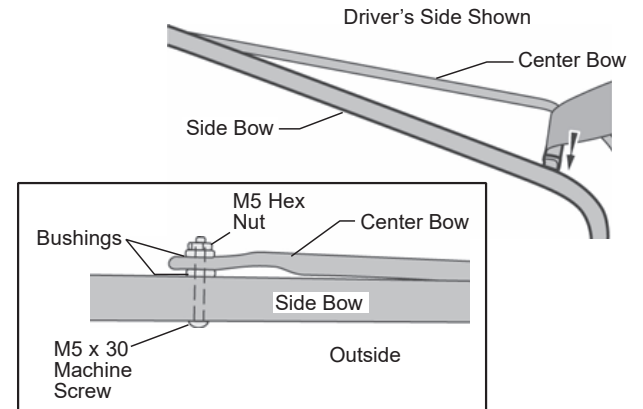



Installation Instructions Supertop NX Twill

Vehicle Application:
Jeep® TJ Wrangler 1997-2006
Part Number 54820

5 Mount Header Assembly to Pivot Bracket

Install the Side Bow Pivot Knuckles onto the upper flange of the Pivot Bracket. Align the knuckle with the bracket and snap it into place.

NOTE For 97 to 02 vehicles equipped with factory installed Pivot Brackets, replace with new Bracket from Kit for proper fit.

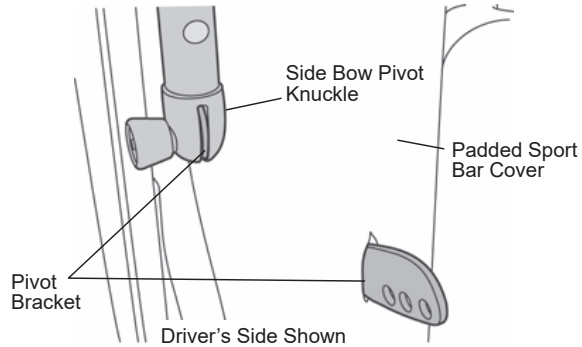

6 Mount Rear Bow Assembly to Pivot Bracket

Install the Rear Bow Pivot Knuckle Assemblies onto the lower flange of the Pivot Bracket. Align the knuckle with the bracket and snap it into place.

If you have a new top, install the Rear Bow Pivot in the front hole.

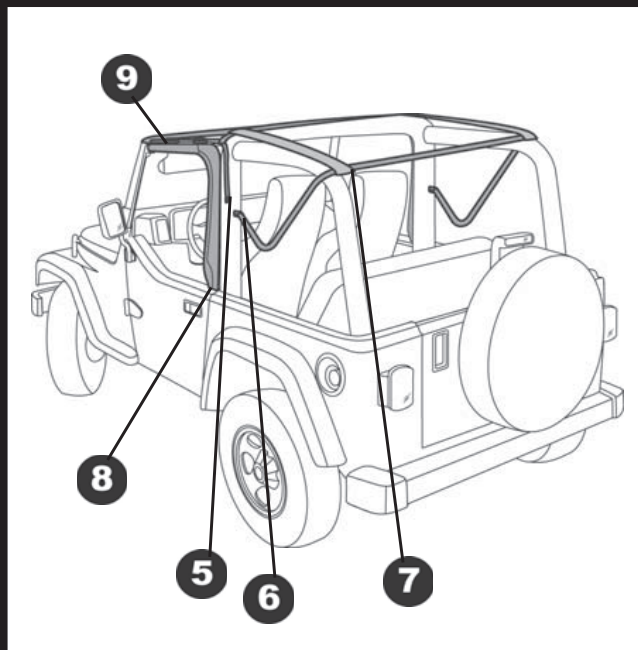
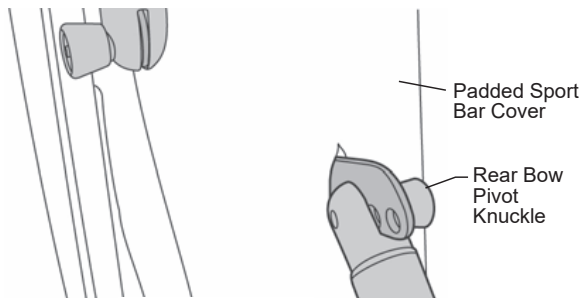

7 Secure Stay Pad to Rear Bow

Rotate the front bow assembly forward, laying the header on top of the windshield. Raise the Rear Bow and pull the fabric Stay Pad attached to the Center Bow straight back to the Rear Bow, without twisting. Align the holes in the Stay Pad with the holes in the corner of the Rear Bow. Install #8 x 1/2" Pan Head Washer Screws in the holes on each side.

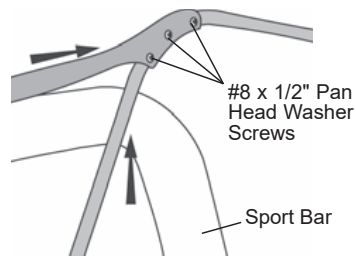

9 Install Door Surround Screws

Press the channels along the top of the Door Surround around the horizontal sport bar, above the door opening. Insert two Screws into the Door Surround and tighten to 55 in/lbs (4.5 ft/lbs)

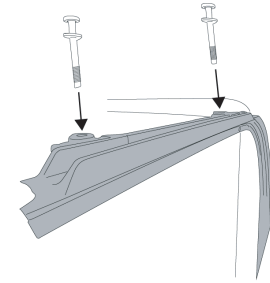

8 Install Door Surrounds

If your vehicle has molded seals on the belt rail, remove them by pulling up on the plastic rivet.

Locate the left and right Door Surrounds. Insert the pin in the bottom of the Door Surround into the hole in the belt rail behind the door.

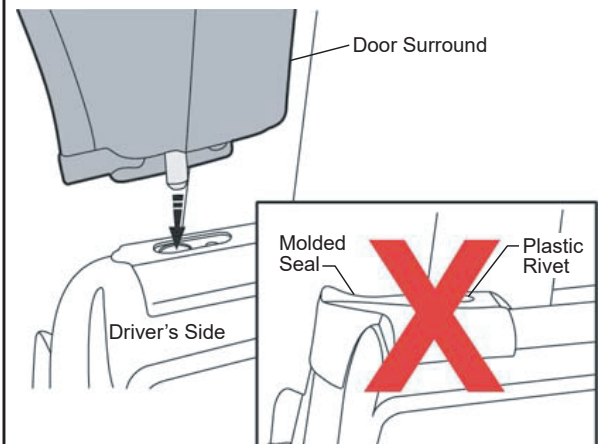



Installation Instructions Supertop NX Twill

Vehicle Application:
Jeep® TJ Wrangler 1997-2006
Part Number 54820

10 Orient Tailgate Mounts

Locate the left and right Tailgate Mounts. Place the holes in the mounts over the dimples in the vehicle body. Mark the hole locations.

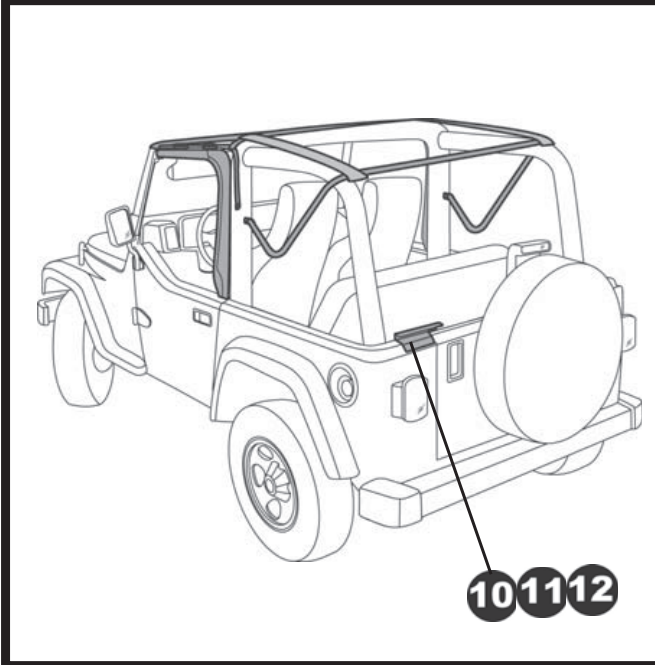
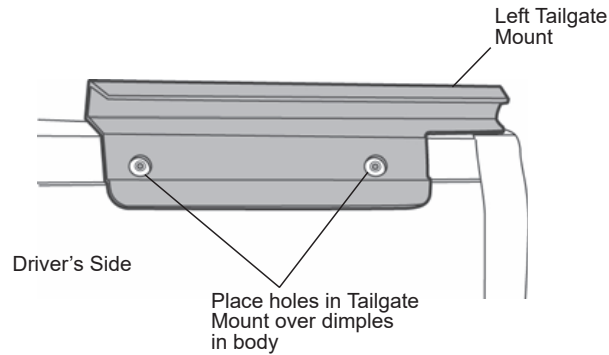

11 Drill Holes

Drill a 1/8" hole at the marked locations. Deburr the holes and seal the edges of the holes with Silicone Sealant.

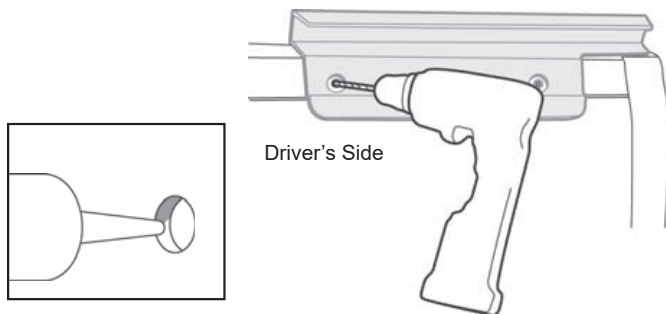

12 Install Tailgate Mounts

Install the Tailgate Mounts with two #8 x 1/2" Pan Head Washer Screws for each mount.

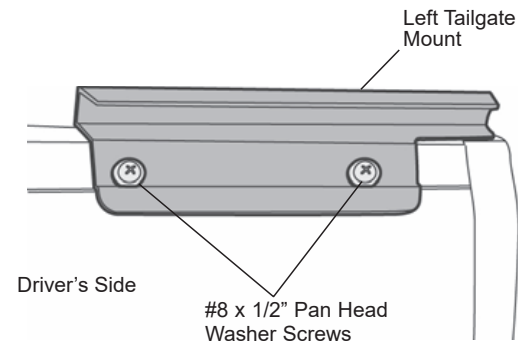



Installation Instructions Supertop NX Twill

Vehicle Application:
Jeep® TJ Wrangler 1997-2006
Part Number 54820

13 Place Top Fabric in Vehicle

Place the Top Fabric in the vehicle with the backing side of the front edge up. Lay the bow assembly down and wrap the front edge of the fabric around the Header.

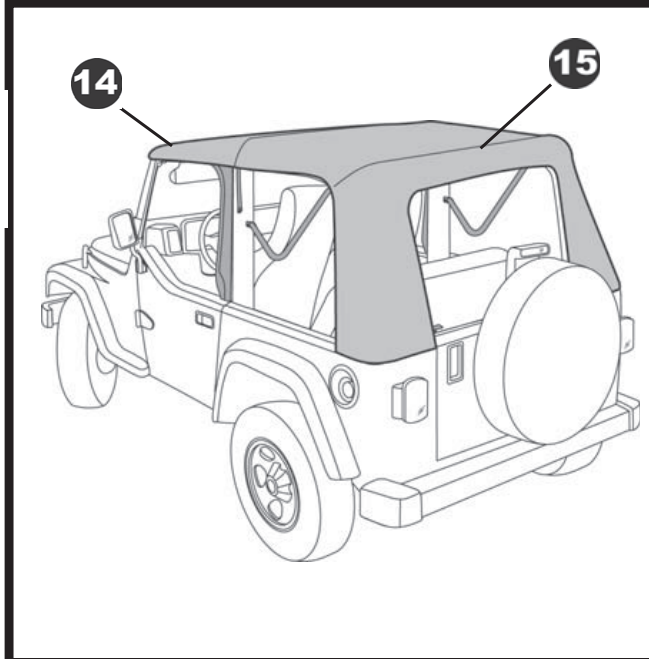
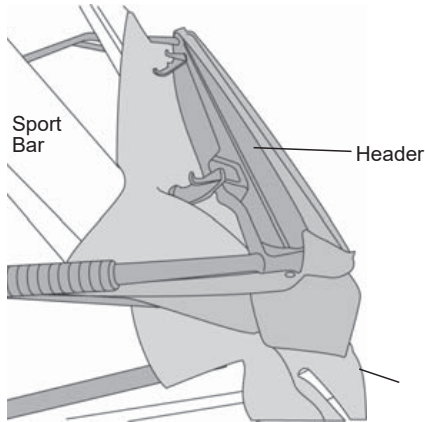

15 Snap Flaps to Rear Bow

Raise the header and bow assembly toward the windshield and into position.
Inside the top, snap the fabric to the Rear Bow (four snaps). Snap the Rear Window Roll-Up Straps to the outer snap on the bow on each side.

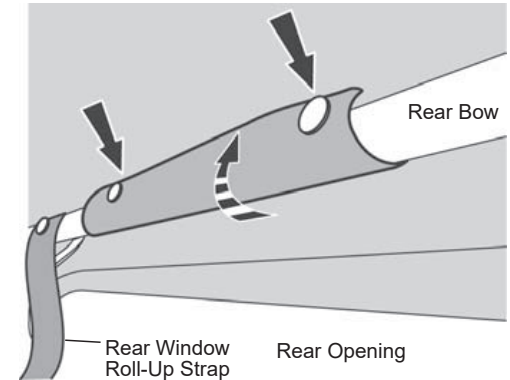

14 Secure Top Fabric to Header

Align the front edge of the fabric with the front edge of the header. Locate the round hole that marks the center of the fabric (all other holes are slotted). Install a #8 x 1/2" Pan Head Washer Screw in the round hole to secure the fabric to the header as well as to center the top. Then install screws in the rest of the eight (8) holes along the front of the header. Install a #8 Oval Head Screw in each corner.

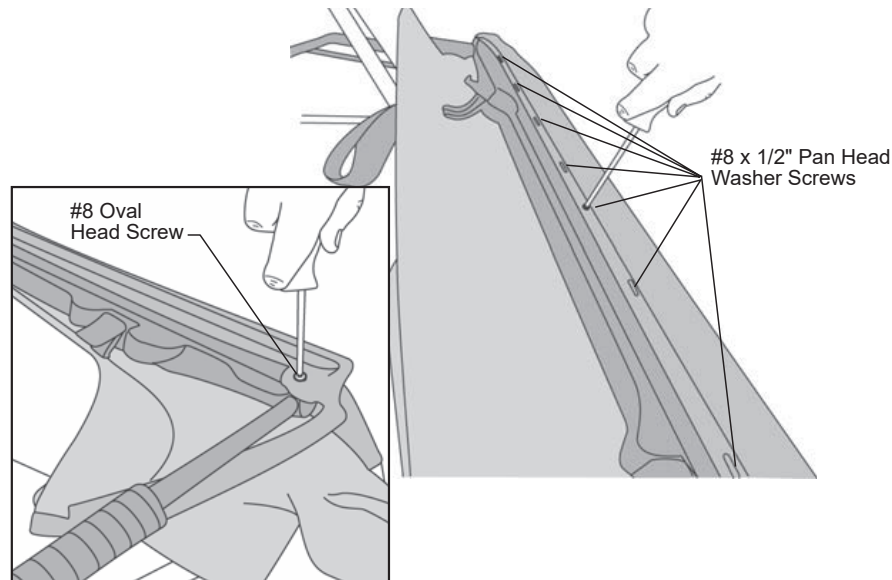



Installation Instructions Supertop NX Twill

Vehicle Application:
Jeep® TJ Wrangler 1997-2006
Part Number 54820

16 Secure Side Bow to Door Surround

Clip the locking block on the Side Bow into the rail on the Door Surround.

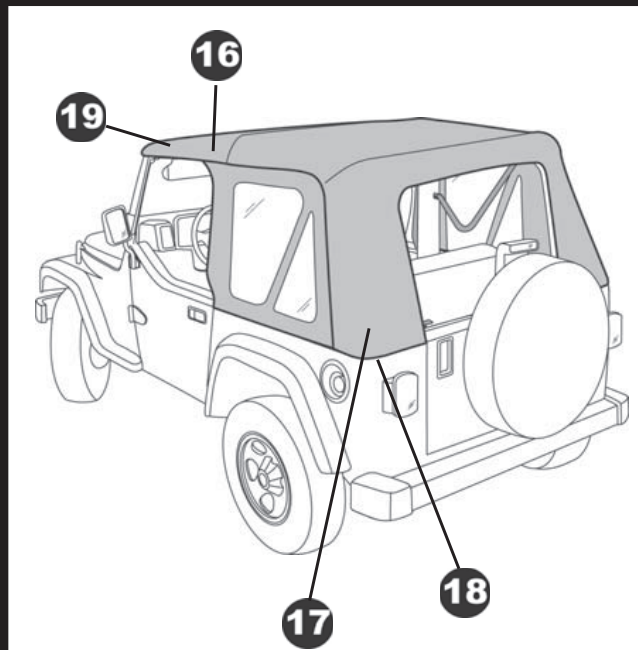
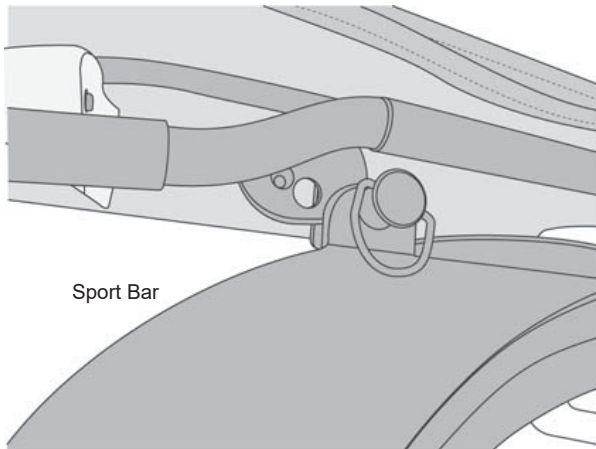

18 Secure Rear Corners

Make sure that the Center Bow is centered in the hook and loop flap inside the top. Do not fasten the flap at this time.

Pull down gently on the Rear Bow and work the plastic sewn to the rear corners of the top into the retainer on the vehicle.

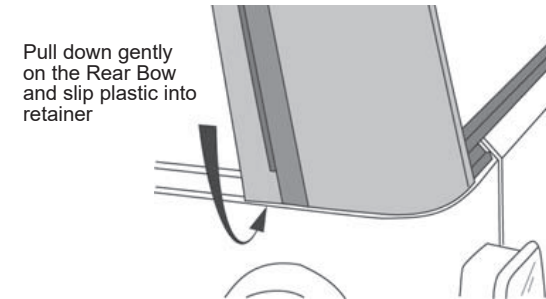

17 Install Plastic Corner Stiffeners

Open the zipper inside the rear corner of the top and install a plastic stiffener in the pocket. Repeat this on both sides of the vehicle.

Install Plastic Stiffener in Pocket

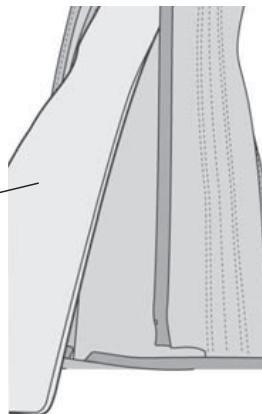

NOTE Make sure the Side bow is latched to the Door surround before you latch the header.

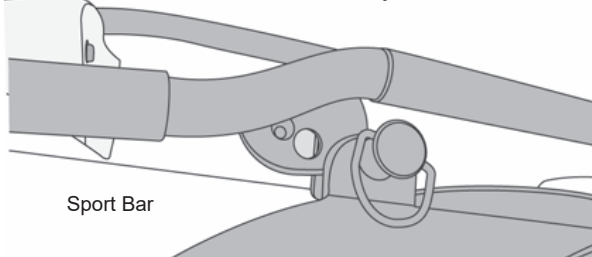

19 Secure Header to Windshield

Close the header latches to secure the front of the top to the windshield. Catch the hook in the slot in the windshield frame and then close the lever over it so that it lays flat against the windshield frame.

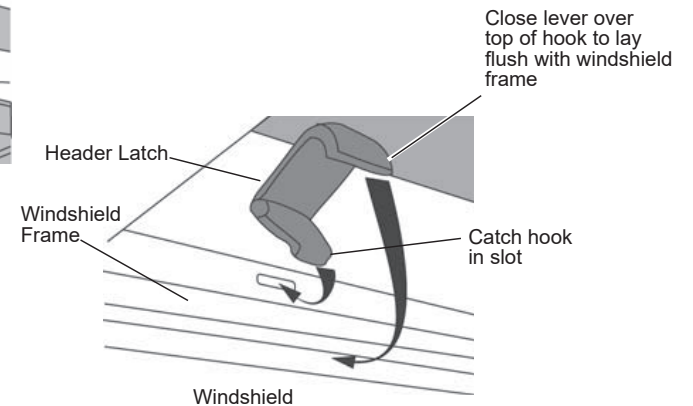



Installation Instructions Supertop NX Twill

Vehicle Application:
Jeep® TJ Wrangler 1997-2006
Part Number 54820

20 Secure Center Bow

Wrap the hook and loop flap inside the top around the Center Bow and fasten it to itself.

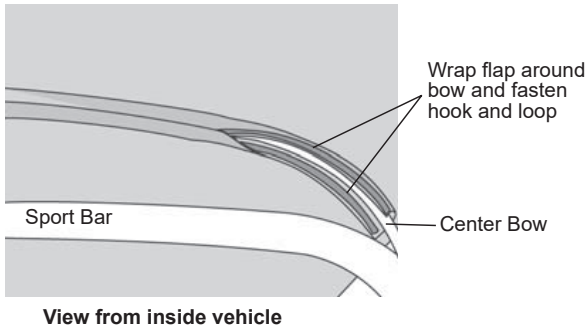

21 Attach Quarter Panel Zippers

Locate the left and right Quarter Panels and orient them with the zipper along the top and rear of the panel. Start the zipper at the front top corner of the Quarter Panel, next to the door. Hold the end of the zipper and close the zipper slider 10" - 12" along the top of the panel.

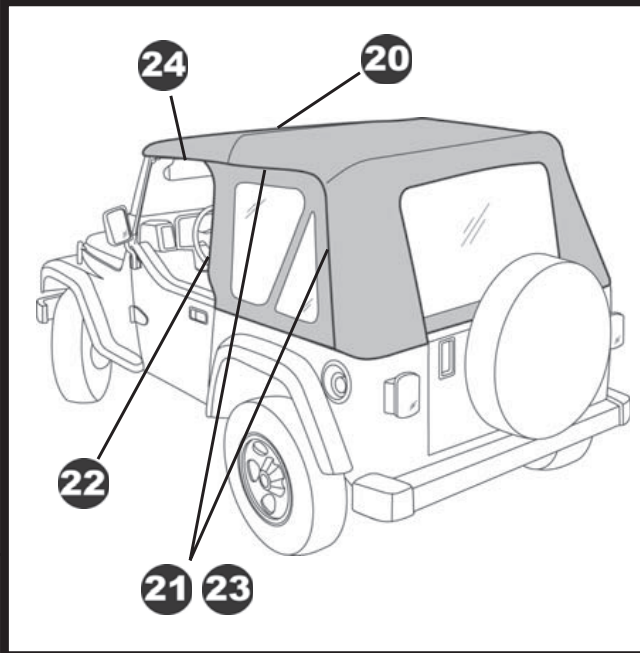
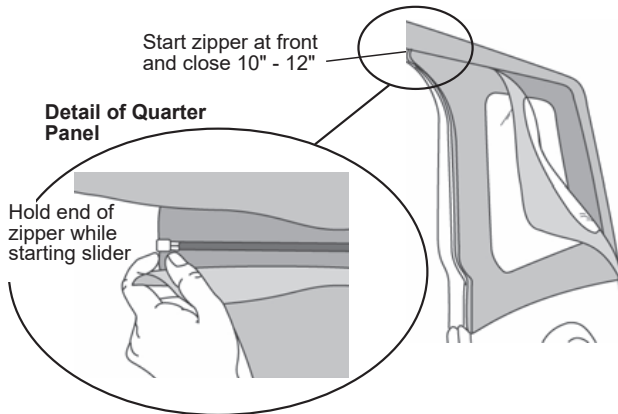

23 Secure Quarter Panels

Close the zippers on the Quarter Panels the rest of the way to the lower rear corner of the panel. Start at the rear and roll the plastic along the bottom of the panel into the retainer on the vehicle. Then fasten the hook and loop strips along the top and rear of the panel to the top.

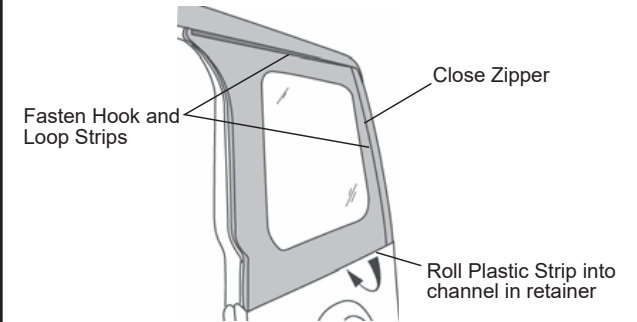

22 Secure Front of Quarter Panels

Roll the plastic along the front of the Quarter Panel into the channel of the Door Surround on the vehicle.

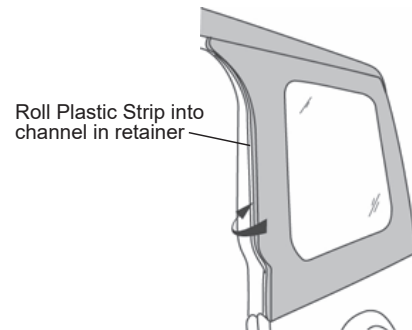

24 Secure Top above Door Openings

Locate the two plastic strips sewn to the sides of the top, above each door. Slip the strips into the channel in the Door Surround above the door opening. It is easiest to insert the front plastic strip into the channel first.

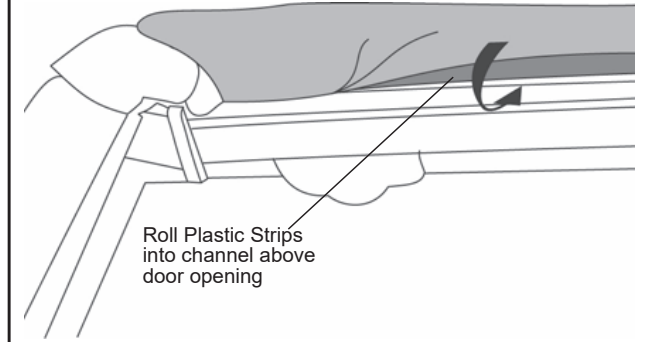



Installation Instructions Supertop NX Twill

Vehicle Application:
Jeep® TJ Wrangler 1997-2006
Part Number 54820

25 Install Tailgate Bar on Rear Window

Remove the Rear Window from the box and lay it flat with the backing side up. Locate the Tailgate Bar set aside in Step One. The bar has a "C" shaped channel, when viewed from the end. Orient the bar with the round seal down and slide the "C" channel on the retainer onto the tubed strip sewn to the backing side of the Rear Window.

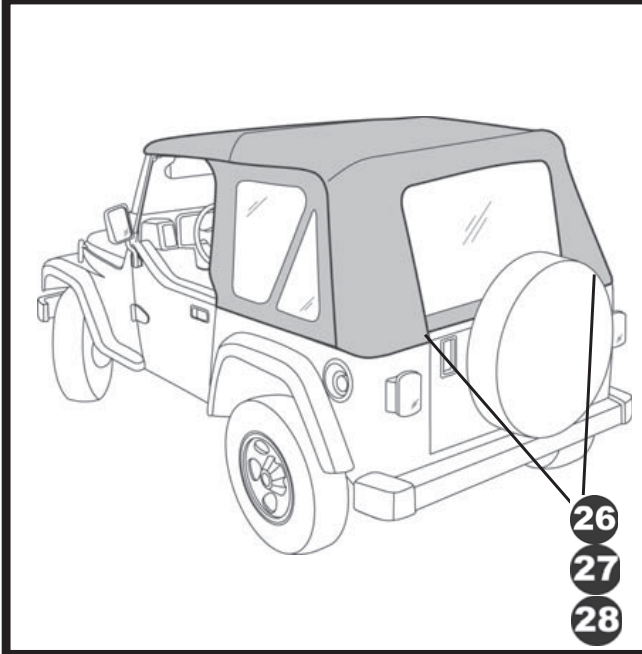
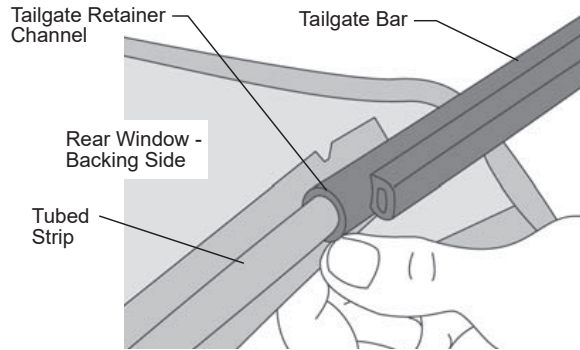

28 Rear Window Flaps

Inside the top locate the flaps sewn to the top on each side of the rear window opening. Pull the flaps over to cover the zipper and tuck them in.

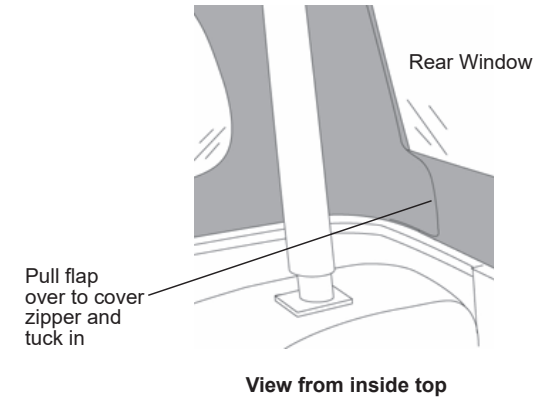

26 Install Tailgate Bar on Vehicle

Insert the Tailgate Bar into the mounts on each side of the tailgate opening with the vinyl side of the Rear Window toward the outside of the vehicle.

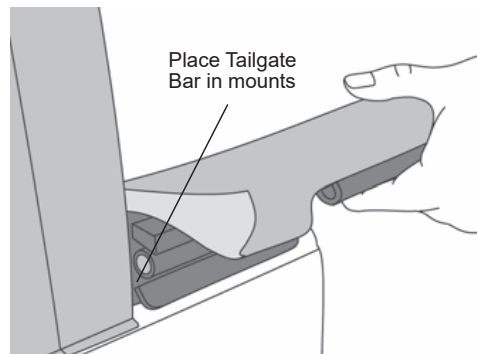

27 Secure Rear Window Zippers

To start the zipper, pull the two sliders as far down as possible on the driver's side of the window in order to catch the sliders to the pin. Once the zipper is caught, start the top slider 1/2". Then hold up the top of the window with one hand and close the zipper with the other. The zipper is sandwiched between layers of fabric in the corners so be careful not to catch extra fabric in the zipper. Close the zipper. Make sure that the Tailgate Bar is centered and is securely in the mounts. Then tuck the flaps on the Rear Window under the tailgate mounts.

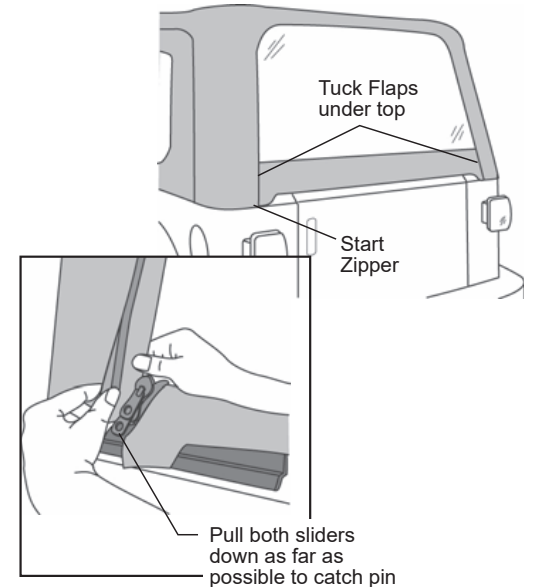



Installation Instructions Supertop NX Twill

Vehicle Application:
Jeep® TJ Wrangler 1997-2006
Part Number 54820

! WARNING When operating the vehicle without the Quarter Windows, the Rear Window should be rolled up and secured with the elastic garters for proper ventilation.

29 To Fold the Top Down Remove Quarter Panels and Rear Window

Remove the Quarter Panels and the Rear Window. To remove the Quarter Windows, unzip the rear and top zippers. Release the plastic strip from the retainer. Release the Hook and Loop Fasteners from around the Vertical Retainer.

To roll up the Rear Window, remove the Tailgate Bar and open the zippers on each side of the window to the top. Start at the bottom and roll the window to the inside. Avoid wrinkles in the fabric and window. Secure it in place with the elastic garters inside of the top.

30 To Fold the Top Down Collapse Top

Release the front of the top from the windshield. Raise the front of the deck and collapse the rear bows, tucking the two plastic strips above the door openings and the stay pad on the rear bow inside of the bows. Wrap the fabric around the bows, then tuck the rear legs of the top under the bows.

Collapse bows and fold toward rear

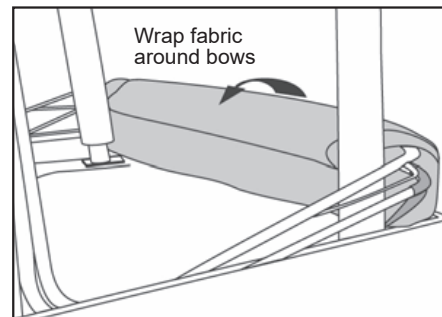
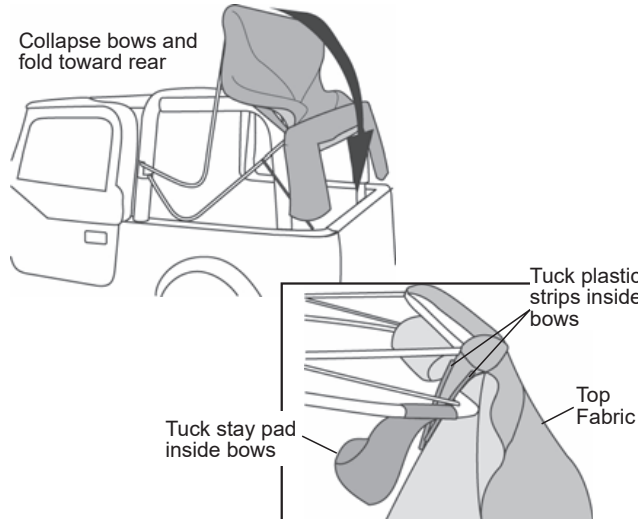



Care and Maintenance of your Bestop Product

Your Bestop product is made of the finest materials available. To keep it looking new and for the maximum possible wear, it will need periodic cleaning and maintenance.

Fabric: The fabric should be washed often using soap, warm water and a soft bristle brush. Rinse with clear water to remove all traces of soap. Bestop recommends using Bestop Cleaner (part no. 11201-00) and Bestop Protectant (part no. 11202-00) for Vinyl fabric and Bestop Twill Protectant (part no. 11207-00) for Twill fabric. Bestop Cleaner and Bestop protectant are specially formulated to provide a total cleaning and protection system. Bestop Cleaner safely removes the toughest stains, will not harm vehicle finishes, is biodegradable and environmentally friendly. Bestop Protectant protects against UV-fading, cracking and hardening, and repels dust, grease, dirt and mildew.

Windows: Keep windows clean to avoid scratching. DO NOT use a brush on the windows! Wash with a water-soaked cloth or sponge and a mild dishwashing detergent. Bestop recommends Bestop Vinyl Window Cleaner (part no. 11203-00), which safely cleans and protects vinyl windows and helps prevent UV damage. NEVER WIPE THE WINDOWS WHEN THEY ARE DRY. Be careful when cleaning snow or frost from the vinyl windows since they are easily scratched and may crack at low temperatures. DO NOT roll the sides or rear window in cold weather. The windows become stiff and will crack. Cracks caused by misuse in cold temperatures are not covered under warranty.

Water: Seeping through at the seams may be stopped by applying 3-M Scotchgard® on the inside of the seams.

Snaps: Keep snaps cleaned and lubricated with silicone to help prevent snaps from sticking to the studs. If a snap does become stuck to a stud, use a screwdriver and GENTLY pry apart to prevent permanent damage to the snap or the top fabric.

Zippers: Keeping zippers cleaned and lubricated with Bestop's Zipper Cleaner (part no. 11206-00) will help prevent damage and keep the zippers in smooth working condition. If a zipper opens behind the slider, the slider may have been spread apart. This problem can usually be repaired by using an ordinary pair of pliers to bring the sides back into parallel. Return slider to the end of the zipper in the normal Open position. Squeeze lightly at first and test the zipper. If the zipper continues to remain open squeeze more firmly with the pliers and try the zipper again. Repeat this procedure until the zipper operates correctly.

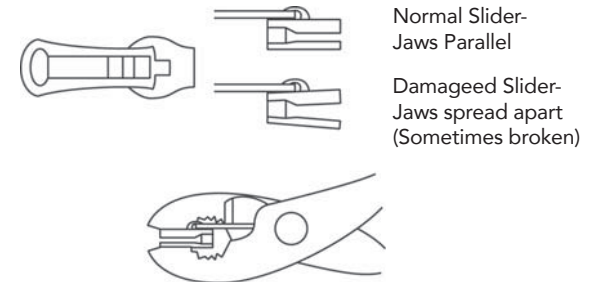

For Bestop Warranty Information, Please go to;
<https://www.bestop.com/help/warranty-information/>

